

STATESMAN

kitchen appliances

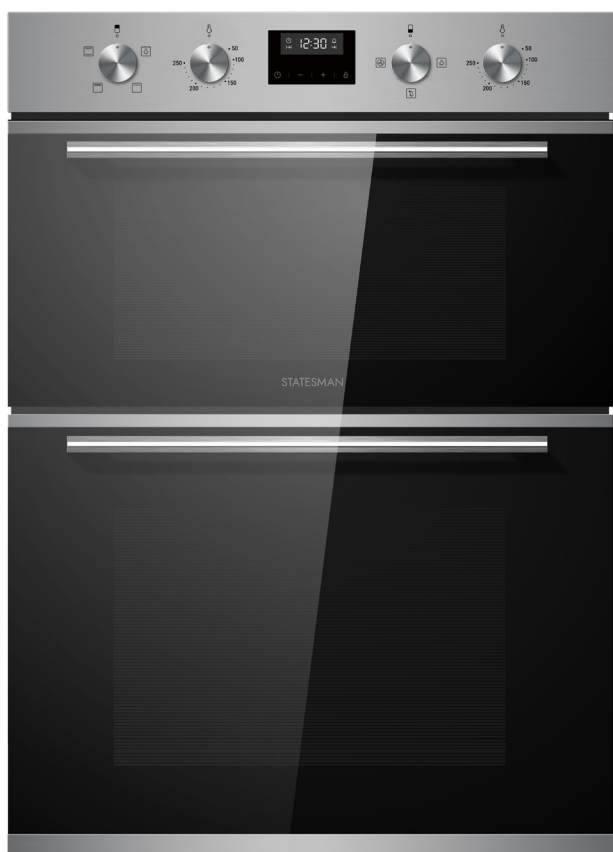

BDM373SS / BDM373BL
BUILT-IN 88CM 35/70L DOUBLE OVEN
STAINLESS STEEL / BLACK

Instruction Manual

Serial number:

**Please read these instructions carefully before use and retain for future reference.
Before switching on your appliance – Always check for any damage that may have
been caused in transit.**

CONTENTS

Important Safety Instructions	3-4
Installation	5-6
Operating Instructions	7-20
- Using the Grill - Electric	7
- Using the Top Oven - Electric (If Fitted).....	8
- Top Oven Baking Guide.....	9
- Using the Main Oven - Electric	10-12
- Main Oven Baking Guide	13-15
- Oven & Grill Functions	16
- Operation	17-18
- Using the Programmer/Clock	19-20
Cleaning & Maintenance	21-23
Troubleshooting Guide	24
Disposal Information	26

SAFETY INSTRUCTIONS

BEFORE USING THE PRODUCT

Make sure that you have removed all packaging and wrapping. Some of the items inside this appliance may have additional wrapping.



WARNING! The appliance and its accessible parts become hot during use. Care should be taken to avoid touching heating elements. Children less than 8 years of age shall be kept away unless continuously supervised.

- This appliance can be used by children aged from 8 years and above and persons with reduced physical sensory or mental capabilities or lack of experience and knowledge if they have been given supervision or instruction concerning the use of the appliance in a safe way and understand the hazards involved. Children shall not play with the appliance. Cleaning and user maintenance shall not be made by children without supervision.



WARNING! Unattended cooking on a hob with fat or oil can be dangerous and may result in fire.

- **NEVER** try to extinguish a fire with water, but switch off the appliance and then cover the flame with a lid or damp cloth.



WARNING! Danger of fire: Do not store items on the cooking surfaces.

WARNING! Servicing should be carried out only by authorised personnel.

- The appliance must never be disconnected from the mains supply during use, as this will seriously affect the safety and performance, particularly in relation to surface temperatures becoming hot. The cooling fan (if fitted) is designed to run on after the control knob has been switched off.
- Do not modify this appliance.
- Prolonged intensive use of the appliance may call for additional ventilation, for example opening of a window, or more effective ventilation, for example increasing the level of mechanical ventilation where present.
- Excess spillage must be removed before cleaning.

WARNING! Do not operate the appliance without the glass door correctly closed.

WARNING! Never put items directly on the base of the oven or cover the oven base with foil, as this can cause the base element to overheat.



WARNING! Do not modify the outer panels of this appliance in any way. **WARNING!** - This appliance must be earthed.

WARNING! Always allow the product to cool down before you change a bulb. There is a risk of electric shock, so always make sure you have turned off and unplugged your appliance before starting.



WARNING! The top element gets extremely hot when in use, so take extra care to avoid touching it.

WARNING! Do not use harsh abrasive cleaners or sharp metal scrapers to clean the oven door glass since they can scratch the surface, which may well result in shattering of the glass.

- **CAUTION:** This appliance is for cooking purposes only. It must not be used for other purposes, for example room heating.



WARNING! If the supply cord is damaged, it must be replaced by the manufacturer, its service agent or similarly qualified persons in order to avoid a hazard.

WARNING! Do not use a steam cleaner to clean any part of the product.

WARNING! The appliance must not be installed behind a decorative door in order to avoid overheating.

- Always take care when removing food from the oven as the area around the cavity may be hot.
- Always use oven gloves when handling any utensils that have been in the oven as they will be hot.
- Always make sure that the oven shelves are resting in the correct position between two runners. Do not place the oven shelves on top of the highest runner, as this is not stable and can lead to spillage or injury.
- Always use the Minute Minder (if fitted) if you are leaving the oven unattended - this reduces the risk of food burning.
- Never place items on the door while it is open.
- Never wrap foil around the oven shelves or allow foil to block the air flue.
- Never drape tea towels near the oven while it is on; this will cause a fire hazard.
- Never pull heavy items, such as turkeys or large joints of meat, out from the oven on the shelf, as they may overbalance and fall.
- Caution: Accessible parts may be hot when the grill is used - young children should be kept away.

INSTALLATION

 This product must be installed by the manufacturers authorised service agent or an equally qualified person.

- Ensure that a safe distance is left between the appliance and the kitchen units / furniture
- Surfaces must be heat resistant to a minimum of 120°C

Fitting the Oven into the Kitchen Unit

- Do not lift the appliance by the door handle.
- Whilst every care is taken to eliminate burrs and raw edges from this product, please take care when handling - we recommend the use of protective gloves during installation.
- Please note that the weight of this appliance is approximately 45kg (unpacked). Take care when lifting it into the housing unit - always use an appropriate method of lifting.
- Leave the fixing screws in the base tray packaging until you are ready to install it. If this appliance is to be installed near to a corner where the adjacent cabinets run at right angles forward of the appliance, there must be a gap of at least 90mm between the appliance and the cabinets, to prevent overheating of the cabinets.

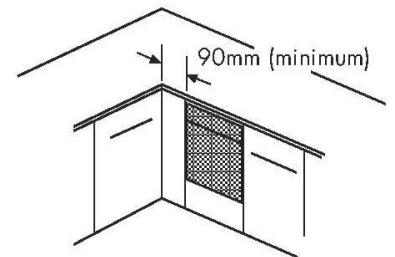

Housing dimensions

The appliance is designed to fit into a standard 600mm wide housing unit with minimum internal dimensions as shown. 590mm is to the underside of the worktop when the appliance is built under, or to the underside of the panel above, when the appliance is installed into a tall housing unit.

1. Fix the two brackets to each side of the cabinet with screws provided. Please set the leading edge of the brackets 50mm from the front edge of the furniture. Please set face A of the brackets 885mm from top of the furniture as illustrated by below picture.
2. Lift and slide the oven onto position on the brackets face A.

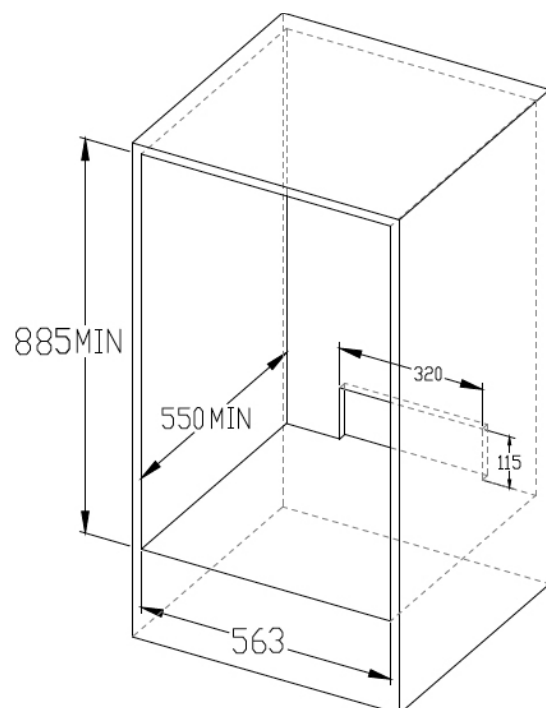
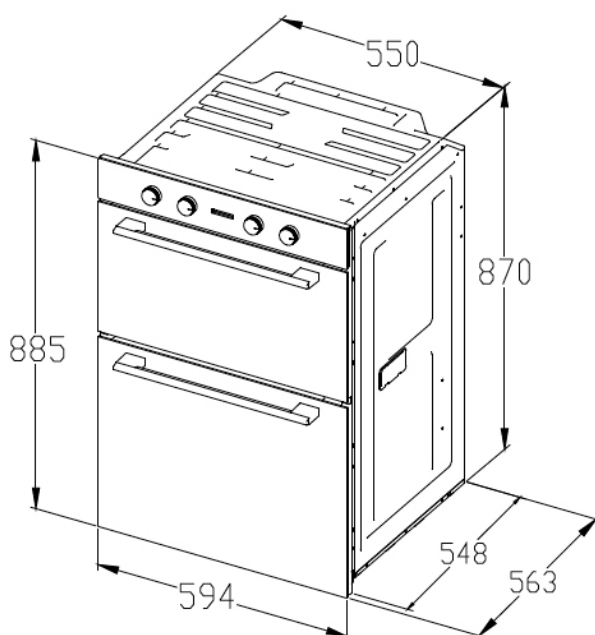

Securing The Oven To The Cabinet

1. Fit oven into the cabinet recess.
2. Open the oven door.
3. Secure the oven to the kitchen cabinet with two distance holders " A " which fit the holes in the oven frame and fit the two screws " B " .

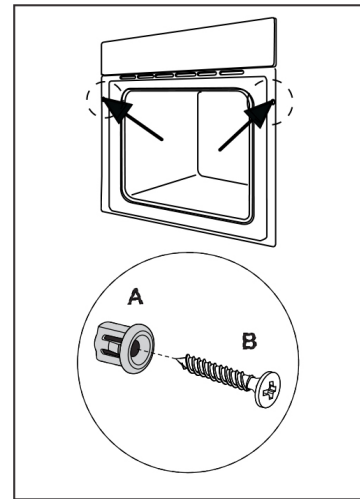

Connection of the Oven

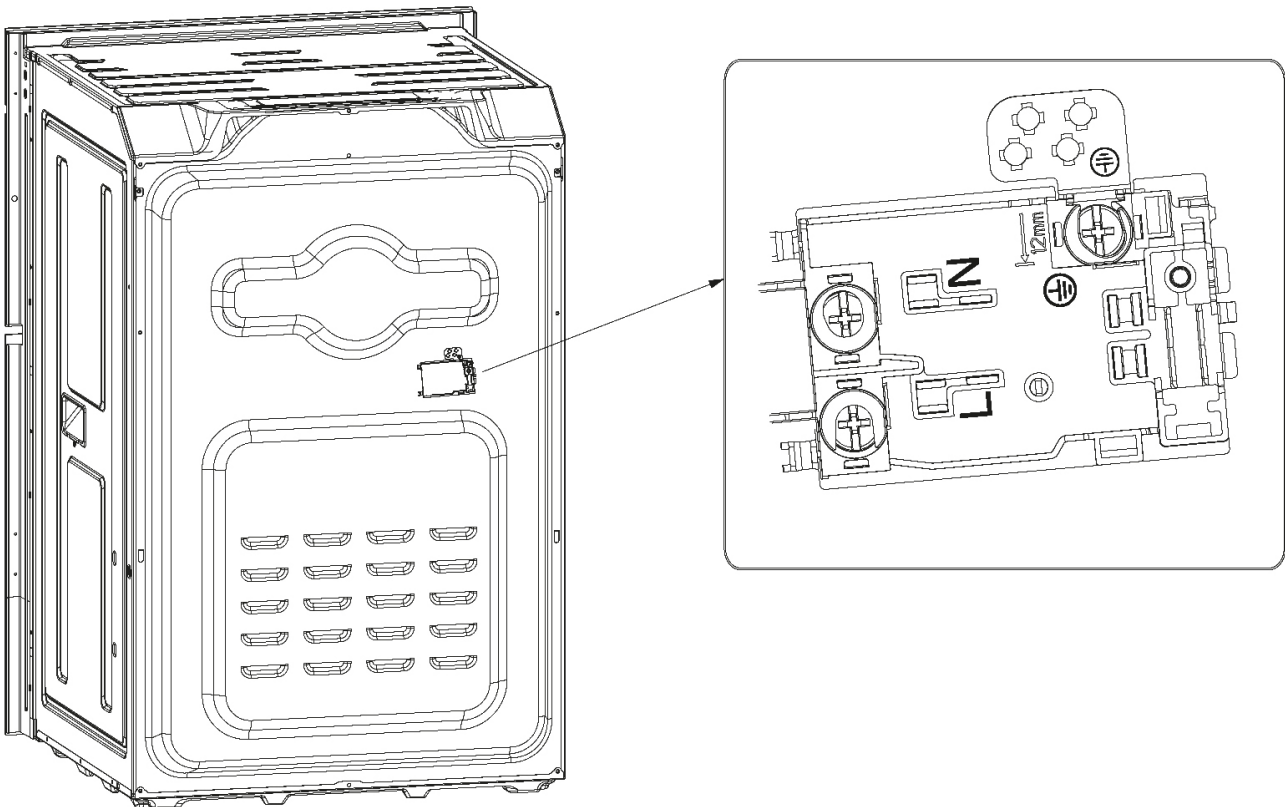

USING THE GRILL - ELECTRIC

Caution: Accessible parts may be hot when the grill is used - young children should be kept away.

If cleaning the grill pan when it is hot, use oven gloves to move it.
Food for grilling should be positioned centrally on the trivet.

Using the TOP Oven Grill

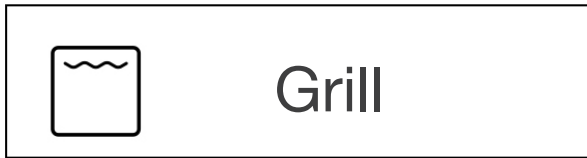

Important: The grill door must be fully open when the grill is used.

open the grill door. Turn the control knob to the required setting. For best cooking results, we recommend that you preheat the single grill for 5 minutes.

push the grill pan towards the back of the shelf, to position it under the grill.

For toasting, and for grilling foods such as bacon, sausages or steaks, use a higher shelf position. For thicker foods such as chops or chicken joint pieces, use a middle to low shelf position.

To switch off, turn the control knob to the off  position.

Using Aluminium Foil

Caution: Using aluminium foil to cover the grill pan, or putting items wrapped in foil under the grill creates a fire hazard.

The Cooling Fan

When the grill is switched on, the cooling fan comes on to keep the fascia and control knobs cool during grilling. During use the fan may cycle on and off, this is normal.

USING THE TOP OVEN - ELECTRIC (IF FITTED)

- When you are cooking keep children away from the vicinity of the oven.
- **Caution: The top element gets extremely hot when in use, so take extra care to avoid touching it.**
- The top oven is a conventional oven.
- **Note:** The top oven is not controlled by the programmer (if fitted).

To Turn on the Top Oven

Turn the temperature control knob until the required temperature is selected.

The red thermostat indicator will come on until the selected temperature is reached, and then go off; it will turn on and off periodically as the thermostat operates to maintain the selected temperature.

To switch off, return the top oven control knob to the off position.

Important: Never put items directly on the base of the oven, or cover the oven base with foil, as this may cause the element to overheat. Always position items on the shelf.

The Cooling Fan

When the top oven is switched on, you will hear the cooling fan come on - this keeps the fascia and control knobs of the appliance cool during cooking.

Preheating

The oven must be preheated when cooking frozen or chilled foods, and we recommend preheating for yeast mixtures, batters, soufflés, and whisked sponges.

Preheat the oven until the indicator light switches off for the first time, this will take up to 15 minutes depending on the temperature selected.

If you are not preheating the oven, the cooking times in the following guide may need to be extended, as they are based on a preheated oven.

Shelf Positions

There are 3 shelf positions which are counted from the bottom of the oven upwards, so shelf position 1 is the lowest.

When cooking frozen or chilled food, use the highest possible shelf position, while allowing some clearance between the food and the top element.

The oven shelf must be positioned with the up-stand at the rear of the oven and facing up.

Position baking trays and roasting tins on the middle of the shelves, and leave one clear shelf position between shelves, to allow for circulation of heat.

When Using the Top Oven

When opening the oven door, care should be taken to avoid any possible contact with potentially hot air, since this may cause discomfort to people with sensitive skin. We recommend that you hold the underneath of the oven door handle.

TOP OVEN BAKING GUIDE

Cooking Times

These times are based on cooking in a preheated oven.

These cooking times are approximate, because the size and type of cooking dish will influence cooking time.

Shelf Positions

As a general guide, when cooking frozen or chilled food, use the highest possible shelf position, while allowing some clearance between the food and the top element. Follow the instructions given on packaging.

Cooking Temperatures

The temperature settings and time given in the Baking Guides are based on dishes made with block margarine. If soft tub margarine is used, it may be necessary to reduce the temperature setting. If a recipe gives a different temperature setting to that shown in the guide, the recipe instruction should be followed.

Because the top oven is more compact, it may be necessary to reduce cooking temperatures specified in recipes by up to 20°C.

Use the baking guide as a reference for determining which temperatures to use.

Item	Temperature (°C)	Shelf Position	Approximate Cooking Time
Small cakes	160 - 170	2	20 - 25 mins
Victoria sponge (2 x 180mm / 7")	160	1	20 - 25 mins
Swiss roll	200	1	8 - 12 mins
Semi rich fruit cake (180mm x 7")	140	1	2¼ - 3¾ hours
Scones	215	1	10 - 15 mins
Meringues	90 - 100	1	2 - 3 hours
Shortcrust pastry	200 - 210	1	depends on size & type of cooking dish & also the filling
Puff / flake pastry	200 - 210	1	
Choux pastry	200 - 210	1	
Biscuits	160 - 200	2	10 - 20 mins
Sponge pudding	150	1	30 - 45 mins
Milk pudding	140	1	2 - 2½ hours

USING THE MAIN OVEN - ELECTRIC

Accessible parts may be hot when the oven is used. Young children should be kept away.

To Switch on the Oven

Turn the oven control knob(s) to the required setting.

The red thermostat indicator (if fitted) will come on until the selected temperature is reached and then go off; it will turn on and off periodically as the thermostat operates to maintain the selected temperature.

To switch off, return the control knob to the off  position.

When Using the Oven

As part of the cooking process, hot air is expelled through a vent in the oven. When opening the oven door, care should be taken to avoid any possible contact with potentially hot air, since this may cause discomfort to people with sensitive skin. We recommend that you hold the underneath of the oven door handle.

PREHEATING

Fanned Oven

When cooking sensitive items such as soufflé and Yorkshire puddings or, when cooking bread, we recommend that the oven is preheated until the indicator switches off for the first time. For any other types of cooking, a preheat may not be required.

Conventional Oven

Preheating is always required

Manual Operation (fanned only)

The Cooling Fan

The cooling fan may operate when the main oven is on and may continue to operate for a period after the oven has been switched off.

OVEN FURNITURE

Oven Shelves

The oven shelf must be positioned with the upstand at the rear of the oven and facing upwards. Position baking trays and roasting tins on the middle of the shelves.

Baking Tray and Roasting Tins

For best cooked results and even browning, the recommended size baking trays and roasting tins that should be used are as follows;

Baking tray 473mm x 370mm

We recommend that you use good quality cookware. poor quality trays and tins may warp when heated, leading to uneven baking results.

Aluminium foil

Use foil only to cover food or cooking dishes, using foil to cover the shelves or oven base creates a fire hazard.

Cooking with a fanned oven

As this is a high efficiency oven, you may notice the emission of steam from the oven when the door is opened. Please take care when opening the door.

If you are used to cooking with a conventional oven you will find a number of differences to cooking with a fan oven which will require a different approach:

- There are no zones of heat in a fan oven as the convection fan at the back of the oven ensures an even temperature throughout the oven. This makes it ideal for batch baking - eg; when planning a party as all the items will be cooked within the same length of time.
- Foods are cooked at a lower temperature than a conventional oven, so conventional recipe temperature may have to be reduced. please refer to the conversion chart.
- Preheating is generally not necessary as a fan oven warms up quickly.
- When batch baking foods that will rise during cooking - eg; bread - always ensure that enough space has been left between the shelves to allow for the rise.

Note: When 2 or more shelves are being used, it may be necessary to increase the cooking time slightly.

- Because the 2 oven shelves are wider than in many ovens, it is possible to cook 2 items per shelf - eg; 2 victoria sponge or 2 casseroles.
- Although you need to keep in mind the points 'To help the air circulate freely' with careful choice of dishes and tins, it is possible to cook a complete meal, and perhaps something else for the freezer, in the oven at the same time.
- When roasting meats, you will notice that fat splashing is reduced, which is due in part to the lower oven temperatures, and will help keep cleaning of the oven to a minimum.
- Because a fan oven has an even temperature throughout the oven, there is no need to follow the shelf positions given in the baking guide.
- There is no need to interchange dishes onto different shelves part way through cooking, as with a conventional oven.

To Help the Air Circulate Freely

Position the shelves evenly within the oven and maintain a clearance from the oven roof and base.

If more than one cooking dish or baking tray is to be used on a shelf, leave a gap of at least 25mm between the items themselves and the oven interior.

Defrosting and Cooling in the Main Oven

To defrost frozen foods, turn the main oven control to the defrost position, place the food in the centre of the oven and close the door.

To cool foods after cooking prior to refrigerating or freezing, turn the main oven control to the defrost position and open the door.

Defrosting Times

- Small or thin pieces of frozen fish or meat e.g. fish fillets, prawns & mince will take approximately 1 - 2 hours.
- Placing the food in a single layer will reduce the thawing time.
- A medium sized casserole or stew will take approximately 3 - 4 hours.
- A 1½kg/3lb oven ready chicken will take approximately 5 hours, remove the giblets as soon as possible.

Be Safe

- Do not defrost stuffed poultry using this method.
- Do not defrost larger joints of meat and poultry over 2kg/4lb using this method.
- Never place uncooked food for defrosting next to cooked food which is to be cooled, as this can lead to cross contamination.
- Defrosting meat, poultry, and fish can be accelerated using this method but make sure they are completely thawed before cooking thoroughly. place meat and poultry on a trivet in a meat tin.

MAIN OVEN BAKING GUIDE



Cooking Times & Temperatures

- The temperature settings and times given in the baking guide are based on dishes made with block margarine. If soft tub margarine is used it may be necessary to reduce the temperature setting.
- Allow enough space between shelves for food that will rise during cooking.
- Do not place items on the oven base as this will prevent air circulating freely.

Note: This is a high efficiency oven, therefore some adjustment will have to be made to conventional cooking temperatures. The table below shows conventional cooking temperatures and 'A' efficiency temperatures. For optimum results, conventional temperatures need to be converted to 'A' efficiency temperatures.

For example, an item which would normally cook at a conventional temperature of 180°C, will now cook at the 'A' efficiency temperature of 160°C.

Conventional Temperature (°C)	'A' Efficiency Oven (°C)
100	100
110	110
130	120
140	130
150	140
160	150
180 - 190	160
200	170
220	180
230	190
250	200

Food Type	Temperature Settings (°C)		Time Approx.	Shelf Position
	Conv.	Fanned		
				
Small Cakes	170	160	15 - 25 min	3
Victoria Sponge	180	160	20 - 30 min	3
Semi Rich Fruit Cake	150	125	2½ - 3 hrs	2
Christmas Cake	150	125	2½ - 3 hrs	2
Bread and Butter Pudding	170	150	45 min - 1 hr	3
Fruit Crumble	200	175	40 min - 1 hr	3
Large Yorkshire Pudding	220	200	40 - 48 min	4 - 5
Small Yorkshire Pudding	220	200	15 - 20 min	4 - 5
Shortcrust Pastry	200	180	depends on filling	4 - 5

Traditional Fruit Cakes

It should be remembered that ovens can vary over time, therefore cooking times can vary, making it difficult to be precise when baking fruit cakes.

It is necessary therefore, to test the cake before removal from the oven. Use a fine warmed skewer inserted into the centre of the cake. If the skewer comes out clean, then the cake is cooked.

- Follow the temperatures suggested in the recipe and then adjust accordingly to the conversion table.
- Do not attempt to make christmas cakes larger than the oven can cope with, you should allow at least 25mm (1 inch) space between the oven walls and the tin.
- Always follow the temperatures recommended in the recipe.
- To protect a very rich fruit cake during cooking, tie 2 layers of brown paper around the tin.
- We recommend that the cake tin is not stood on layers of brown paper, as this can hinder effective circulation of air.
- Do not use soft tub margarine for rich fruit cakes, unless specified in the recipe.
- Always use the correct size and shape of tin for the recipe quantities.

Roast Turkey

Roasting turkey involves cooking two different types of meat - the delicate light breast meat, which must not be allowed to dry out, and the darker leg meat, which takes longer to cook.

The turkey must be roasted long enough for the legs to cook, so frequent basting is necessary.

The breast meat can be covered once browned.

- Always make sure that the turkey is completely thawed and that the giblets are removed before cooking.
- Turkey should be roasted at 160°C
- 180°C (fanned) or 180°C - 200°C (conventional) for 20 minutes per 450g (1 lb), plus 20 minutes, unless packaging advises otherwise.
- The turkey can be open roasted, breast side down, for half of the cook time, and then turned over for the remainder of the cooking time.
- If the turkey is stuffed, add 5 minutes per 450g (1 lb) to the cooking time.
- If roasting turkey covered with foil, add 5 minutes per 450g (1 lb) to the cooking time.
- To test if the turkey is cooked, push a fine skewer into the thickest part of the thigh. If the juices run clear, the turkey is cooked. If the juices are still pink, the turkey will need longer cooking.

Roasting guide

The times given in the roasting guide are only approximate, because the size and age of the bird will influence cooking times as will the shape of a joint and the proportion of the bone.

Frozen meat should be thoroughly thawed before cooking. For large joints it is advisable to thaw over night.

Frozen poultry should be thoroughly thawed before cooking. The time required depends on the size of the bird - eg; a large turkey may take up to 48 hours to thaw.

Use of a trivet with a roasting tin will reduce fat splashing and will help to keep the oven interior clean. Alternatively, to help reduce fat splashing, potatoes or other vegetables can be roasted around the meat/poultry.







Notes:

- When cooking stuffed meat or poultry calculate the cooking time from the total weight of the meat plus the stuffing
- For joints cooked in foil or covered roasters, and for lidded casseroles, add 5 minutes per 450g (1lb) to the calculated cooking time.
- Smaller joints weighing less than 1.25kg (2½lb) may require 5 minutes per 450g (1lb) extra cooking time.
- Position the oven shelf so that the meat or poultry is in the centre of the oven.
- It is recommended that the appliance is cleaned after open roasting.

Cook in main oven at: 160°C - 180°C (fanned) 180°C - 200°C (conventional)		Approximate Cooking Time (preheated oven)
Beef	Rare	20 minutes per 450g (1lb), plus 20 minutes
	Medium	25 minutes per 450g (1lb), plus 25 minutes
	Well Done	30 minutes per 450g (1lb), plus 30 minutes
Lamb	Medium	25 minutes per 450g (1lb), plus 25 minutes
	Well Done	30 minutes per 450g (1lb), plus 30 minutes
Pork		35 minutes per 450g (1lb), plus 35 minutes
Poultry		20 minutes per 450g (1lb), plus 20 minutes

OVEN & GRILL FUNCTIONS

The chart below details all of the functions which are available.

Symbol	Function/Feature	Recommended Uses
	Grill, Small Area	For grilling small amounts of steaks, sausages, toast and pieces of fish. The centre part of the grill heating element becomes hot.
	Grill, Large Area	For grilling steaks, sausages, toast and pieces of fish. The whole area below the grill heating element becomes hot.
	Conventional Grill	This function is ideal for traditional roasting. The meat is placed in the middle of the oven, roast potatoes towards the top.
	Fanned Oven	The even temperature in the oven makes this function suitable for batch baking, or batch cooking foods.
	Defrosting and Cooling	To defrost foods, such as cream cakes/gateaux, use with the oven door closed. For cooling dishes prior to refrigeration, leave the door open.
	Oven Temperature Control	Use to select the oven temperature.
	Lights Only	Use when the oven is switched off and cold to aid cleaning the oven.

Manual Operation

The programmer must be set to manual operation before the main oven or grill functions can be used.

To Turn on the Main Oven

- Step 1 - Select the function
Turn the selector control knob in either direction, until the function you require appears in the window.
- Step 2 - Set the main oven control If you have selected an oven cooking function, then simply turn the main oven temperature control knob to the required temperature - this brings on the neon indicator light, which will stay on until the oven reaches the required temperature. To switch off the main oven, return the control knob to the off position.

Automatic Operation

See 'programmer / clock' section.

Using The Main Oven

Caution: Accessible parts may be hot when the appliance is in use - keep children away from the vicinity of the oven.

Never put items directly on the base of the oven or cover the oven base with foil, as this can cause the base element to overheat.

Manual Operation

Set the programmer to manual operation. See 'programmer / clock' section. Turn the selector control knob to the symbol for the desired oven function. Turn the main oven temperature control knob to the desired temperature. The red thermostat indicator light will come on and off until the selected temperature is reached and then go off; it will turn on and off periodically as the thermostat operates to maintain the selected temperature.

To switch off the main oven, return the main oven control knob to the off position.

Automatic Operation

See 'programmer / clock' section.

Preheating

Always use the fan oven setting for preheating to save time and electricity. After the oven has been preheated on the fan oven setting, turn the selector control knob to the oven setting you require. The oven must be preheated when cooking frozen or chilled food, and we recommend preheating for yeast mixtures, batters, soufflé and whisked sponges, otherwise preheating is not necessary as a fan oven warms up quickly. preheat the oven until the indicator light switches off for the first time; this will take between 5 - 15 minutes, depending on the temperature selected.

To Help the Air Circulate Freely

- Position the shelves evenly within the oven and maintain a clearance from the oven roof and base.
- If more than one cooking dish or baking tray is to be used on a shelf, leave a gap of at least 25mm between the items themselves and the oven interior.
- Allow enough space between shelves for food that will rise during cooking.
- Do not place items on the oven base as this will prevent air from circulating freely.



Fan Oven

- Turn the selector control knob to the base heat symbol.
- Turn the main oven control knob to the required temperature.

The fan oven comes on when the oven is switched on and circulates the air around the oven to give a fairly even temperature throughout the oven.



Defrosting and Cooling

- Turn the selector control knob to defrost
- Turn the oven control to the light symbol.

To defrost frozen foods, place food in the centre of the oven and close the door.

To cool foods after cooking prior to refrigeration or freezing, place food in the centre of the oven with the door open.

CAUTION

- **Do not defrost stuffed poultry using this method.**
- **Do not defrost larger joints of meat or poultry over 2kg / 4lb using this method.**
- **Never place uncooked food which is to be defrosted next to cooked food which is to be cooled, as this can lead to cross contamination.**

Please refer to the cooking Guide for more information on using the defrost function.

USING THE PROGRAMMER / CLOCK

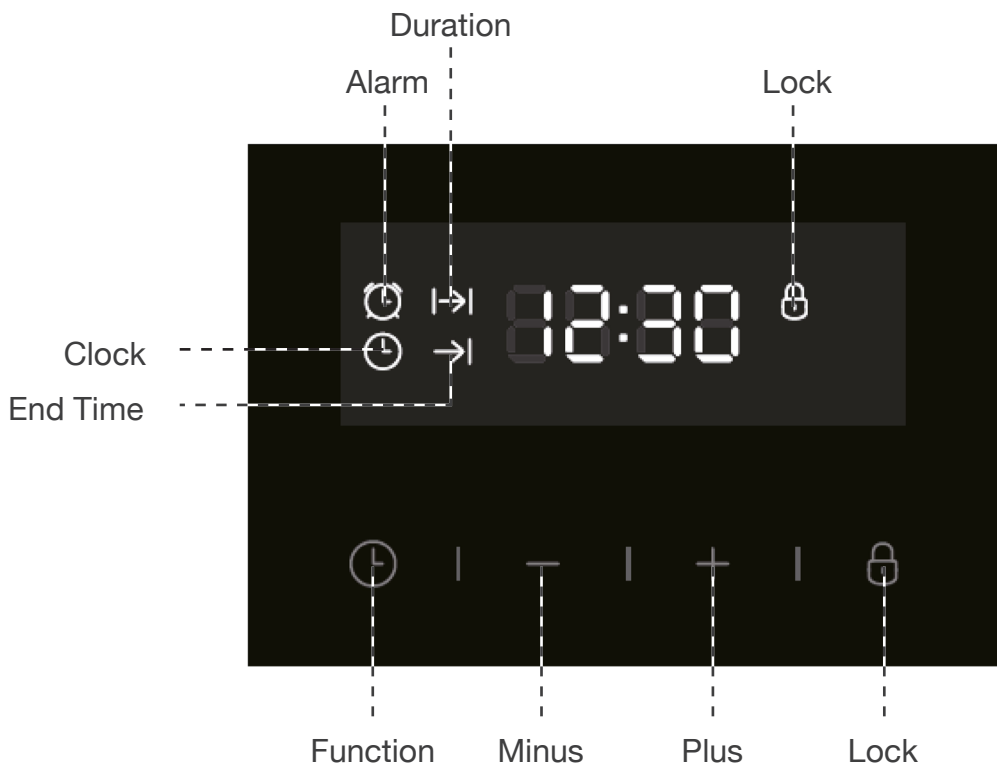

After power on, '0:00' and the clock icon will flash on the screen, press any button to quit.

Button 1: Function - * clock > alarm setting > duration setting > end time setting > clock setting >

* clock (*: default)

Button 2: minus (-)

Button 3: plus

Button 4: Lock

Set Alarm

1. Press button 1, alarm icon flashing means alarm function chosen. "0:00" will display. Press button 2 and 3 to set alarm time. Time adjust range is "0:01~23:59". Press once to plus or minus 1, and hold for 3 seconds for quick-adjust. Wait for 5 seconds to confirm setting, the alarm icon will display, alarm time will be shown and alarm starts. After the count down, "0:00" will display, buzzing starts 4 times every 5 seconds. Press any button to stop.
2. If there's no operation for 2 minutes, buzzing will stop.

Duration Setting

1. Press button 1, choose 'duration' function, duration icon will flash, "0:00" will display. Press button 2 and 3 to set duration time, adjusting range is "0:01~23:59". Press once to plus or minus 1, hold for 3 seconds for quick-adjust. The flashing will last for 5 seconds, so the settings must be done within this time frame or the time of day will show again. After setting, the duration icon will display, counting down starts. When counting down stops, power will turn off, 'Duration' icon will flash, "0:00" will display, buzzing will start twice for every 5 seconds. Press any button to stop buzzing, and press button 1 to show the time of day.
2. During the cooking duration, press button 1 to check and change the cooking time.
3. After counting down, if there's no operation for 2 minutes, buzzing will stop.

Time Function

1. Press button 1 to choose time function. Time icon will flash, press button 2 or 3 to set time. The range is 24hrs. Press once to plus or minus 1, hold for 3 seconds for quick-adjust. No operation for 5 seconds, the time of day will show, time icon will turn off.
2. If time setting is changed after setting alarm, duration and end time, the alarm will not be changed, and duration and end time will reset.

Lock Function

1. Press lock button for 3 seconds any time, the lock function will become active, and lock icon will display. Press lock button for 3 seconds again, it will be unlocked. The icon turns off.
2. When locked, pressing any button will cause buzzing, meanwhile the lock icon will flash for 3 seconds.

Other Notification

1. If setting alarm, duration time and end time, alarm time will display, and alarm, duration, end time icons will display.
2. After setting alarm, duration, and end time, Button 1 can be pressed to check and change alarm time, duration time, end time and day time.
3. If duration time is later than alarm time, there will be only buzzing for alarm. If duration is earlier than alarm time, there will be only buzzing for alarm.

CLEANING & MAINTENANCE

General

- It is important to clean the product regularly as a build up of fat can affect its performance or damage it and may invalidate your guarantee.
- Always switch off your appliance and allow it to cool down before you clean any part of it.
- Do not use undiluted bleaches, products containing chlorides, wire wool or abrasive cleaners on aluminium, stainless steel, or plastic/painted parts as they can damage the appliance. Nylon pads can also be unsuitable.
- Take extra care when cleaning over symbols on fascia panels. Excessive cleaning can lead to the symbols fading.
- If your product is fitted with stainless steel cladded strips. You may notice a small white residue on the outer edges, this can be removed with a non abrasive wipe.

Painted & Plastic Parts

- Only use a clean cloth wrung out in hot soapy water.
- Do not use abrasive cleaners, wire or nylon cleaning pads on these parts.

Stainless Steel & Aluminium Surfaces

- Only use a clean cloth wrung out in hot soapy water, and dry with a soft cloth.
- Stubborn marks can be removed using a stainless steel cleaner. Supplies can be purchased from the customer care centre.
- Sharp objects can mark the surface of stainless steel, but will become less noticeable with time.
- Wipe any spillage immediately, taking care to avoid burning your hands
- Some foods are corrosive eg; vinegar, fruit juices and especially salt - they can mark or damage the metal if they are left on the surface.
- Baby oil can be used to restore stainless steel finish - but only use a few drops. don't use cooking oils as they can contain salts, which will damage the metal.
- Do not use steam cleaners.

Enamel Surfaces & Parts

- Clean with warm, soapy water and a clean cloth.
- If larger splashes of fat do not readily disappear, you can use a mild cream cleaner to remove them. More stubborn marks can be removed using a soap filled pad.
- Rinse well and dry with a soft clean towel or cloth.
- Do not use steam cleaners.

WARNING: Do not use harsh abrasive cleaners or sharp metal scrapers to clean the oven door glass since they can scratch the surface, which may result in shattering of the glass.

- Only use a clean cloth wrung out in hot soapy water, or a specialist glass cleaner. Rinse away any excess cleaner and dry with a soft cloth.

Chrome Plated Parts

- Use a moist soap filled pad, or place in a dishwasher.

REMOVING OVEN PARTS FOR CLEANING

- To remove the door, open the door to the maximum angle. Then pull the buckle at the door hinge backward.
- Close the door to an angle approximately 30°. Hold the door with one hand on each side.
- Lift up and slowly pull the door out from the oven.
- The inner door glass panel can be removed for cleaning but it must be replaced the right way up. If there is any writing on the glass, you must be able to read it clearly when the cavity doors are open.
- Always make sure that the glass is pushed fully into the Stop position.
- To remove the glass panel, open the door wide, push the clips on the left and right sides of door bracket. Then remove the plastic top cover. Hold the glass and slide it out along the door bracket.

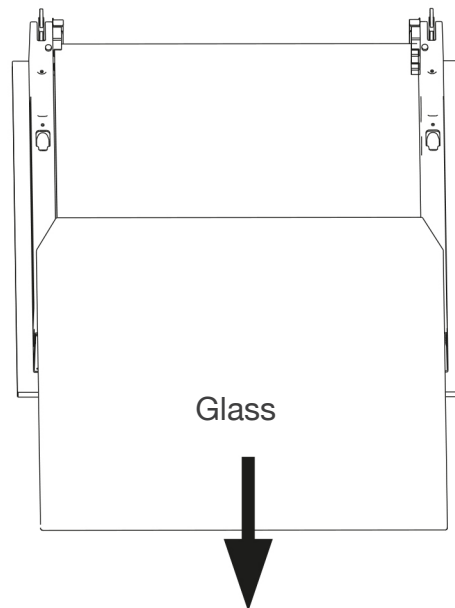
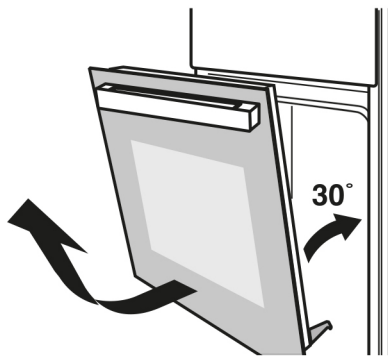
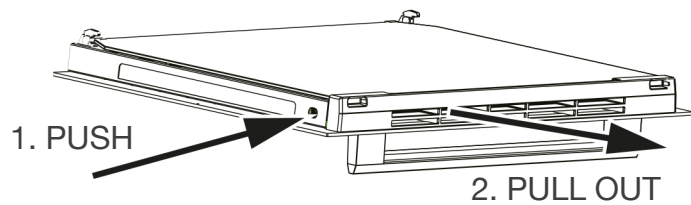
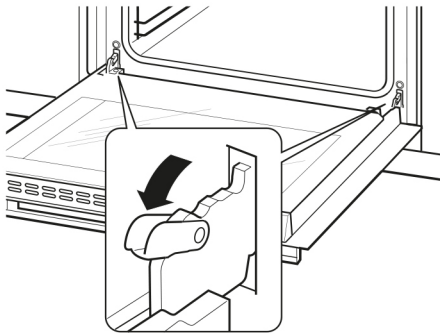

Warning: Do not operate the appliance without the glass panel correctly fitted.

For your safety, glass door panels are made of toughened glass. This ensures that, in the unlikely event that a panel breaks, it does so into small fragments to minimise the risk of injury. Please take care when handling, using or cleaning all glass panels, as any damage to the surfaces or edges may result in the glass breaking without warning or apparent cause at a later date. Should any glass panel be damaged, we strongly recommend that it is replaced immediately.

Shelf Runners

- Shelf runners can be removed to enable you to clean them thoroughly. Make sure they are cool to touch and then grasp the runners and slide out of their hanging holes.

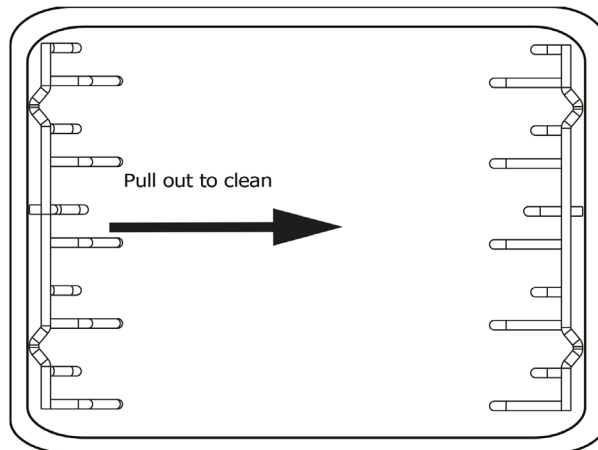

BULB REPLACEMENT

For replacement, process as follows:

1. Disconnect power from the mains outlet or switch off the circuit breaker of the unit's mains outlet.
2. Unscrew the glass lamp cover by turning it counter-clockwise (note, it may be stiff) and replace the bulb with a new one of the same type.
3. Screw the glass lamp cover back in place.

NOTE: Only use 25-40W/220V-240V , T300°C halogen lamps.

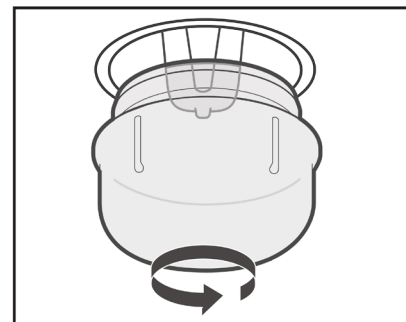

TROUBLESHOOTING GUIDE

If you are having problems with your appliance, please use our troubleshooting guide below. If you are unable to resolve the issue using this guide, please ring our Customer Service Department on 0844 848 5861. Please have the model code and purchase information available.

SYMPTOM	CAUSE / SOURCE	USER ACTIONS / SOLUTIONS
Oven will not heat.	Oven is set for delay timed cooking	Oven will turn on automatically at preset time. Press CANCEL to return to normal operation.
	Faulty heating element	Call for service.
	Door not shut tightly.	Check for obstructions, and close door tightly.
No time is displayed or the time is incorrect.	Time of day is not set.	Set clock by reference of user manual
Oven lamp will not work.	Light bulb was burned out.	Replace light bulb.
Door outer glass broken.	Damaged after shipping.	Call for service.
Door inner glass broken.	Damaged after shipping.	Call for service.
	Cold item placed on hot glass	Call for service.
	Item dropped on window pack	Call for service.
Food is burnt or oven bakes unevenly.	Food placed in oven during pre-heat	Verify the food is not in oven before pre-heat
	Food may be too close to the heating element.	Put the bake rack or bake tray on right position
	Temperature setting too high for recipe or quantity of food	Check temperature setting. Verify temperature setting against recipe

Disposal of Old Electrical Appliances

The European Directive 2002/96/EC on Waste Electrical and Electronic Equipment (WEEE), requires that old household electrical appliances must not be disposed of in normal unsorted municipal waste. Old appliances must be collected separately in order to optimise the recovery and recycling of the materials they contain and reduce the impact on human health and the environment. The crossed out “wheeled bin” symbol on the product reminds you of your obligation, that when you dispose of the appliance it must be separately collected. Consumers should contact their local authority or retailer for information concerning the correct disposal of their old appliance.



STATESMAN
kitchen appliances

**38 Bluestem Road,
Ransomes Europark
Ipswich, IP3 9RR**

0844 848 5861