

STATESMAN

kitchen appliances



BSF60WH / BSF60SS / BSF60BL

BUILT IN ELECTRIC FAN OVEN

Instruction Manual

PO Number:

**Please read these instructions carefully before use and retain for future reference.
Before switching on your appliance – Always check for any damage that may have
been caused in transit.**

CONTENTS

Important Safety Instructions.....	3
Specifications.....	5
Installation.....	6-14
Cleaning and Maintenance	15
Troubleshooting Guide	15
Disposal Information	16
Service and Spare Parts	17
Warranty & Registration	18

SAFETY INSTRUCTIONS

Important: This appliance is not intended for use by persons including children with reduced physical, sensory or mental capabilities, or lack of experience and knowledge.

- This product must be installed by the manufacturers authorised service agent or a qualified electrician. Failure to use a qualified person will result your warranty being void.
- Before starting any work on electrical installation please turn off the electricity supply at the mains.
- Ensure that the fuse rating is correct.
- This appliance must be earthed.
- The supply cable must not come into contact with any hot surfaces.
- The appliance and its accessible parts become hot during use.
- Do not touch the heating elements when the appliance is in use or when the elements are still hot. Heating elements should only be changed by an authorised service agent or a qualified electrician.
- Do not allow children to play with the appliance.
- Do not allow children to go near the oven when it's operating, especially when the grill is on.
- Do not use harsh abrasive cleaners or sharp metal scrapers to clean the glass of the oven.
- This can scratch the surface and may result in permanent damage to the glass.
- During use, the appliance becomes very hot.
- Use heat resistant gloves when removing hot items from the oven.
- Ensure that the appliance is switched off before replacing the oven lamp to avoid the possibility of electric shock.
- The means for disconnection must be incorporated in the fixed wiring in accordance with the wiring specifications.
- Do not touch the oven with wet or damp hands or feet.
- Do not place any items on the oven door. It may damage the door and/or hinges and may unbalance the oven.



WARNING: During cooking never place pans or cookware on the base of the oven. They should be placed on to the wire shelves.

- Some parts of the appliance may keep its heat for a long time; please allow the oven to cool down before touching any parts of the cavity or accessories.
- If the appliance will remain unused for long periods of time you are advised to turn the oven off at the mains supply.
- If the supply cord is damaged, it must be replaced by the manufacturer, its service agent or a qualified electrician in order to avoid a hazard.
- Only use utensils / oven trays which have been deemed oven safe by the manufacturer.
- A pressurised steam cleaner should not be used.
- The appliance should not be used for space heating.
- Take care when cooking dishes which contain alcohol. Alcohol evaporates at high temperatures and can cause a fire. Please follow the recipe guidelines carefully.
- Do not use sealed food containers or glass jars. Heat will build pressure inside of the containers which could cause the container to shatter.

SPECIFICATIONS

Voltage	220-240V~
Total Power Consumption	2100W
Grill Power Consumption	2000W
Fuse Protection	13 Amps
Cable Length	1m
Cable Type	3G1.5 mm ² H05VV-F
Energy Rating	A
Interior Lamp Wattage	25W

INSTALLATION



This product must be installed by the manufacturers authorised service agent or a qualified electrician.

- Ensure that a safe distance is left between the appliance and the kitchen units / furniture
- Surfaces must be heat resistant to a minimum of 120°C
- The dimensions attached are in mm.

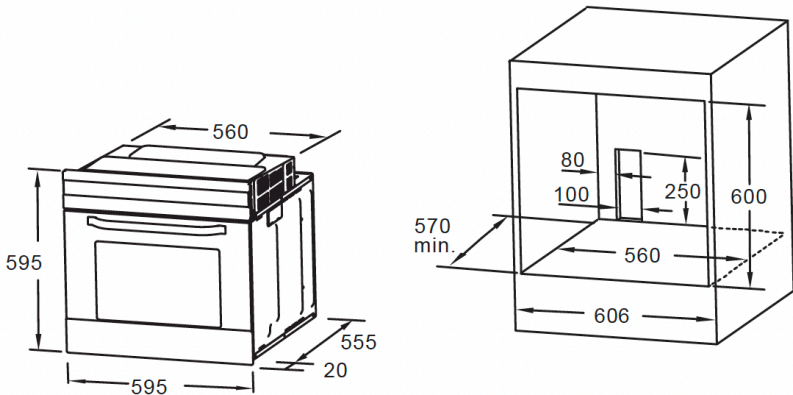

Fitting the Oven into the Kitchen Unit

1. The oven must be lifted by a minimum of 2 persons.
2. Do not use the oven door handle to lift the appliance. Use the slots / handles at the side of the unit.
3. Fit the oven into the space provided in the kitchen unit; it may be fitted underneath a work top or into an upright cupboard. Fix the oven in position by screwing into place, using the two fixing holes in the frame. To locate the fixing holes, open the oven door and look inside. To allow adequate ventilation, the measurements and distances must be adhered to when fixing the oven.

Securing the Oven to the Cabinet

1. Fit oven into cabinet recess
2. Open the oven door and determine the location of the mounting screw holes.
3. Fix the oven to the cabinet with the distance holders 'A' and screws 'B' .

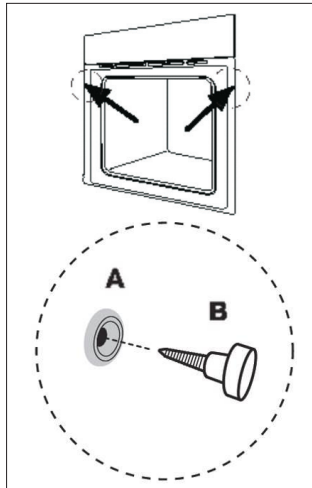

Important: If the oven is to work properly, the kitchen housing must be suitable. The panels of the kitchen unit next to the oven must be made of a heat resistant material.

Ensure that the glues of the units are made of veneered wood can withstand temperatures of at least 120°C. Plastics or glues that cannot withstand such temperatures will melt and deform the unit. Once the oven has been lodged inside the units, electrical parts must be completely insulated. This is a legal safety requirement.

All guards must be firmly fixed into place, so that it is impossible to remove them without using special tools. Remove the back of the kitchen unit to ensure an adequate current of air circulates around the oven. The hob must have a rear gap of at least 45mm.

Electrical Connection - The appliance is supplied with a 13 amp cable pre-fitted.



- This product must be installed by the manufacturers authorised service agent or a qualified electrician. Before starting any work on electrical installation please turn off the electricity supply at the mains. Ensure that the fuse rating is correct.

- This appliance must be earthed.
- The supply cable must not come into contact with any hot surfaces.
- If the supply cable is found to be damaged do not install the product. This lead must be changed by a qualified electrician only.
- The supply cable should not be trapped between the appliance and the wall

Changing the Supply Cable

- The supply cable must correspond to the to the correct specification and power consumption (See Technical Specification on page 2)
- Open the terminal block cover with a screwdriver.
- Pass the supply cable through the cable clamp under the terminal and fix the supply cable using the screw provided.
- Correctly connect the cable according to the diagram below.
- Close the terminal black cover once complete.

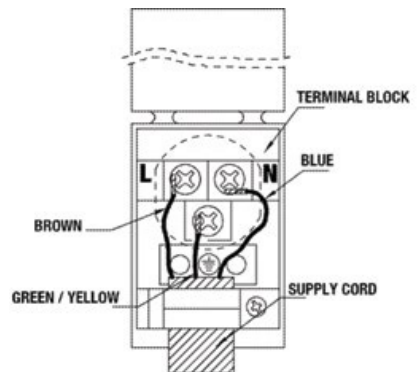
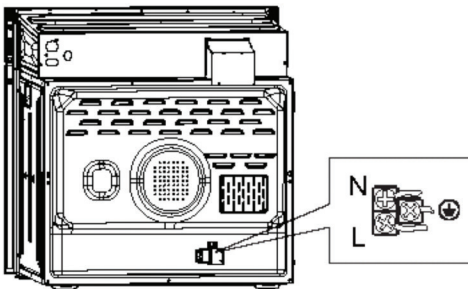

Before First Use

When you have unpacked the oven, make sure that it has not been damaged in anyway. If you have any doubts at all, do not use it: contact a qualified electrician. Keep packing materials such as plastic bags or polystyrene out of the reach of children because these are dangerous.

To remove any residue from the oven which may have been left from the manufacturing process you should select the convection and fan oven function and set the thermostat to the maximum temperature setting. Leave the oven on for a maximum of 40 minutes.



WARNING: The oven may emit an odour and /or smoke when first heated. Please ensure that the room is well ventilated and wait for the smell inside the cavity to clear before cooking any food.

Once the oven cavity has cooled wipe the surfaces of the appliance with a clean damp cloth / sponge and dry with a cloth. Wash all oven accessories in water with a mild detergent before use. Do not use any abrasive cleaners on the oven cavity or accessories as this may damage the surface.

Function Control

Grill Function

The inner grill elements will switch on and off to maintain the temperature set. For best results place food on the top shelf. Please Note: Food must not touch the grill elements

Fan Assisted Grilling

Operation as above with fan to ensure even distribution of heat

Fan Assisted Oven

A fan located in front of the oven element distributes hot air around the oven cavity to ensure even cooking. Perfect for when cooking on multiple levels.

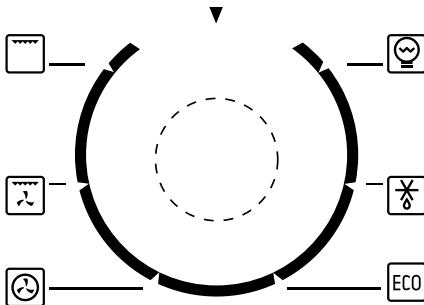

Oven Light

Defrost Function

The circulation of air at room temperature enabling quicker thawing of frozen food.

For energy-saved cooking. Cooking the selected ingredients in a gentle manner, and the heat comes from the back heater.

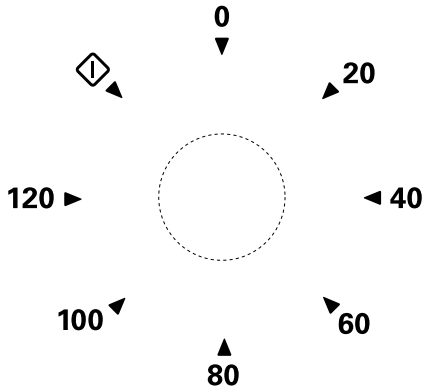

Mechanical Timer

To set the time of cooking by turning the timer knob to desired time per your food cooking guide. After the cooking time is up, the timer will go off.

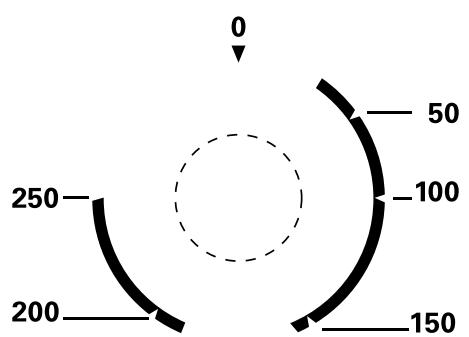

Thermostat Control

Set the temperature by turning the temperature control. If the unit is not in use, always set the control to "0".

Accessories

2 Wire shelves:

For roasting and grilling.

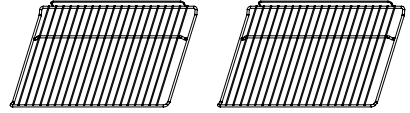

1 Universal Pan:

For cooking large quantities of food, also for collecting fat/spillage and meat juices

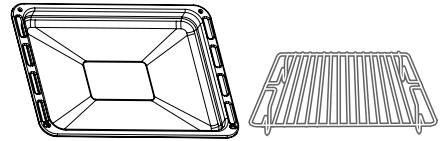

- Please refer to the information given on the food packaging for guidance on cooking temperatures and times.
- You should always pre-heat the oven and do not place food inside the cavity until the operating indicator light has switched off. If you choose not to pre-heat the oven then cooking times should be extended by at least 10 minutes.
- You should always pre-heat the oven if you are baking.
- Make sure that frozen foods have thawed thoroughly unless the food packaging states that the item can be cooked from frozen.
- Any accessories that are not required should be removed from the oven before cooking.
- Place cooking trays in the centre of the oven and leave gaps between the shelves to allow air to circulate.
- Do not open the oven door if not necessary. The internal light will allow you to monitor the progress without opening the door.
- Keep the oven door closed during all cooking functions including grilling.
- Do not use aluminium baking foil when using the grill. The high reflectivity of the foil could potentially damage the grill element.
- You should never line the base of the oven with aluminium foil.
- During cooking never place pans or cookware on the base of the oven. They should be placed on to the wire shelves.
- The grill element and other internal components become extremely hot during operation. Avoid touching them inadvertently when handling the food which you are grilling.

- Take care when opening the oven door to avoid contact with hot parts of the oven and steam.
- Always use an oven glove when removing cookware from the oven.
- Keep children away from the oven when in use.
- Do not allow children to play with the oven.

Shelf Positions

- Insert the oven shelf and baking tray between the side rails on both sides at any level.
- The oven shelf has a safety stop for accidental withdrawal. After placing the oven shelf into the side rails, as you push the oven shelf into the oven lift the oven shelf slightly to bypass the stops and allow the oven shelf to slide fully into the rails.
- To remove the oven shelf, gently pull the oven shelf outwards. When the shelf stops, lift the front slightly to bypass the safety stops and then completely withdraw the shelf from the oven.

Ventilation

When cooking is finished, if the cavity temperature is above 70°C the cooking fan will continue to work for 15 minutes after the oven stops cooking. This is normal operation and does not indicate a fault.

Bulb replacement

The lamp in the light has a high temperature resistance
(230V~25W)

For replacement, proceed as follows:

1. Disconnect power from the mains outlet or switch off the circuit breaker of the mains outlet.
2. Unscrew the covering glass and replace the bulb with a new one of the same specification.
3. Screw the covering glass back in place.

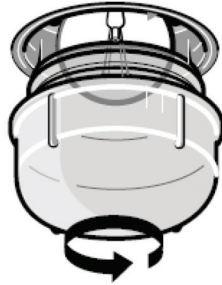

WARNING: This appliance must be removed from the mains power supply before you attempt to remove or replace the appliance lamp.

Removing the Oven Door



WARNING: Do not attempt to disengage the hinge locks on the door whilst it is removed from the oven.



WARNING: The hinge springs could release, causing personal injury



WARNING: Do not lift or carry the oven door by the door handle

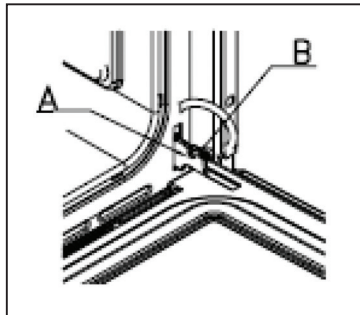

For easy cleaning the oven door can be removed as follows:

- The hinges (A) have two bolts on them. If you raise both of the movable bolts (B) then the hinges (A) will be released from the oven housing.
- You should grip the sides of the door at the centre and then incline it slightly at a 15° angle then pull the door gently away from the oven cavity.
- To replace the door, slide the hinges back into their clots and open the door fully.

Please Note: You should make sure that the oven door is supported at all times and that you place the door on soft padded material when cleaning.

Removing the Side Racks

To thoroughly clean the oven it may be necessary to remove the side racks.

- Remove the oven shelves and the enamel baking tray from the cavity.
- Unscrew the bolt on the bottom of each rack with a screwdriver and then unhook each side rack at the top. Pull them away from the cavity.
- To reassemble the side racks, hook the upper struts into the relevant holes in the cavity and then secure the lower bolts.

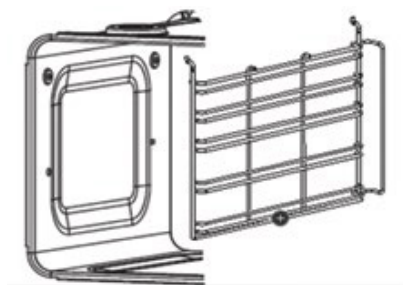

Recipes for ECO Mode

Recipes	Temperature (°C)	Level	Time (min)	Pre-heat
Potato Cheese Gratin	180	I	90-100	No
Cheese Cake	160	I	100-150	No
Meatloaf	190	I	110-130	No

CLEANING AND MAINTENANCE

- Before any maintenance and cleaning, disconnect the appliance from the mains power supply.
- Set all controls in the OFF position.
- Wait until the inside of the unit has cooled.
- Clean the surface of the unit with a damp cloth, soft brush or fine sponge and wipe dry. In case of heavy soiling, use hot water with non-abrasive cleaning product.
- For cleaning the glass of the oven door, do not use abrasive cleaners or sharp metal scrapers, these can scratch the surface or lead to glass being damaged.
- Never leave acidic substances (lemon juice, vinegar) on stainless steel parts.
- Do not use a high pressure cleaner for cleaning the unit. The baking pans may be washed in mild detergent.

Problem	Possible Cause	Solution
Oven does not switch on.	Power is switched off.	Check whether there is power supplied. Also check that other kitchen appliances are working.
No heat or oven does not warm up.	Oven temperature control is incorrectly set. Oven door has been left open.	Check that the oven temperature control knob is set correctly.
Cooking is uneven within the oven.	Oven shelves are incorrectly positioned.	Check that the recommended temperatures and shelf positions are being used. Do not frequently open the door unless you are cooking things that need to be turned. Opening the door often means that the interior temperature will be lower, and this may affect the results of your cooking.
Oven light (if available) does not operate.	Lamp has failed. Electrical supply is disconnected or switched off.	Replace lamp according to instructions. Make sure the electrical supply is turned on at the wall socket outlet.
The oven fan (if available) is noisy.	Oven shelves are vibrating.	Check that the oven is level. Check that the shelves and any bakeware are not vibrating or in contact with the oven back panel.

DISPOSAL INFORMATION

The European Directive 2012/19/EU on Waste Electrical and Electronic Equipment (WEEE), requires that old household electrical appliances must not be disposed of in normal unsorted municipal waste.



Old appliances must be collected separately in order to optimise the recovery and recycling of the materials they contain and reduce the impact on human health and the environment.

The crossed out “wheeled bin” symbol on the product reminds you of your obligation, that when you dispose of the appliance it must be separately collected. Consumers should contact their local authority or retailer for information concerning the correct disposal of their old appliance.

SERVICE AND SPARE PARTS

Should you experience any difficulty in using your Statesman appliance at any time, you may contact your Statesman Retailer or call our Customer Service Department on 01473 277 508;

Please have the following details ready;

- Model Name/ Model Number
- Serial Number
- Date of Purchase
- Where Purchased
- Customer Name and address including post code
- Contact Telephone Number
- Accurate description of the fault

Spare Parts information can be obtained by calling our Spare Parts Department on 01473 277 508

Disclaimer

Updates to hardware components are made regularly. Therefore some of the instructions, specifications and pictures in this documentation may differ slightly from your particular situation. All items described in this guide are for illustration purposes only and may not apply to your particular situation. No legal right or entitlements may be obtained from the description made in this manual.

Suppliers name	STATESMAN
Model	BSF60BL /BSF60SS /BSF60VWH
Energy efficiency index (EElcavity)	94
Energy class	A
Energy consumption per cycle in forced air mode	0.79kWh/cycle
Number of cavity	1
The heat source per cavity	Electricity
Volume of each cavity	70L

STATESMAN WARRANTY/GUARANTEE TERMS & CONDITIONS

THANK YOU FOR CHOOSING STATESMAN

As a valued customer we would like to offer you a **FREE 2-year warranty** to cover your product against any electrical or mechanical defects.

This means that in the unlikely event you develop a fault or problem with your product we will happily repair or replace the item free of charge.

To qualify for the guarantee, the product must be used for domestic household use only and in accordance with the instructions in the user manual. Any misuse of the product will result in the warranty being void.

The guarantee does not cover accidental damage, misuse, neglect, tampering or incorrect adjustment or installation.

The guarantee will be rendered invalid if the product is resold, has had its serial number or rating label removed (or has an invalid serial number or rating label), or if an unauthorised person has carried out any repairs or alterations.

The warranty does not cover accessories or consumable parts that require replacement under normal use. This includes shelving, dials, filters, belts and trays etc.

In the unlikely event of a breakdown please refer to the Troubleshooting Guide in your user manual and check all plugs, fuses and the electricity supply.

If you still require assistance, please contact our Customer Service Department on **01473 277 508** or write to us at the following address:

**Customer Service Department
38 Bluestem Road, Ransomes Industrial Estate, Ipswich, IP3 9RR**

Please quote the Product Code and the PO number on the rating label and give details of the exact fault. We will then decide whether to replace the item.

IMPORTANT NOTE: Before we arrange the replacement, you will be required to return a copy of your proof of purchase. Please retain your original.

If an item is replaced within the agreed warranty period, the warranty for the replacement item will be calculated from the purchase date of the original.

In the event that the product is inspected, and no fault is found, or the product is not within the guarantee period you will be charged for the repair and any carriage costs.

STATESMAN
kitchen appliances

**38 Bluestem Road, Ransomes Europark, Ipswich, IP3 9RR
EU: Castle Electrical Factors Ltd., Dundalk, A91 KA9R, IR**

01473 277 508