

STATESMAN

kitchen appliances



MD018362NI
180CM MULTI DOOR TNF FRIDGE
FREEZER INOX

Instruction Manual

Please read these instructions carefully before use and retain for future reference.
Before switching on your appliance – always check for any damage that may have been caused in transit.

CONTENTS







Important Safety Instructions	3-5
Technical Specification	6
Appliance Overview.....	7
Installation.....	8 - 10
Operating Instructions	11 - 16
Cleaning and Maintenance	17
Trouble Shooting Guide	18
Fuse Replacement.....	19
Disposal Information	20
Statesman Warranty Information.....	21

IMPORTANT SAFETY INSTRUCTIONS

Read and follow all the instructions even if you feel you are familiar with the product and find a place to keep this manual handy for future reference.

When using electrical appliances, basic safety precautions should always be followed:

- This appliance can be used by children aged from 8 years and above and persons with reduced physical, sensory, or mental capabilities or lack of experience and knowledge if they have been given supervision or instruction concerning use of the appliance in a safe way and understand the hazards involved.
- Children aged from 3 to 8 years are allowed to load and unload this appliance.
- Children should be supervised to ensure that they do not play with the appliance.
- Cleaning and user maintenance should not be carried out by children unless they are aged from 8 years and above and are supervised.
- Keep all packaging well away from children. There is a risk of suffocation.
- If you are discarding the appliance, pull the plug out of the socket, cut the power cable (as close to the appliance as you can) and remove the door, to prevent children playing with the appliance and suffering electric shock or getting locked inside.
- If this appliance featuring magnetic door seals is to replace an older appliance having a spring lock (latch) on the door or lid, make sure that the spring lock is unusable before you discard the old appliance. This will prevent the risk of anyone getting trapped inside the appliance.

-  **WARNING!** Always keep the ventilation openings clear of obstruction. Should they become blocked, clear them straight away.
-  **WARNING!** Do not use mechanical devices or other means to accelerate the defrosting process, other than those recommended by the manufacturer.
-  **WARNING!** Do not damage the refrigerant circuit.
-  **WARNING!** Do not use other electrical appliances (such as ice cream makers) inside of the appliance unless they are approved for this purpose by the manufacture.
-  **WARNING!** Do not touch the light bulb if it has been on for a long period of time because it could be very hot.
-  **WARNING!** When positioning the appliance, ensure the power cord is not trapped or damaged.
-  **WARNING!** Do not locate multiple portable socket-outlets or portable power suppliers at the rear of the appliance.

- Do not store explosive substances such as aerosol cans with a flammable propellant in this appliance. The refrigerant isobutane (R-600a) is contained within the refrigerant circuit of the appliance, a natural gas with a high level of environmental compatibility, which is flammable.
- During transportation and installation of the appliance, be certain that none of the components of the refrigerant circuit become damaged.
 - Avoid open flames and sources of ignition.
 - Thoroughly ventilate the room in which the appliance is situated.
- It is dangerous to alter the specifications or modify this product in any way. Any damage to the cord may cause a short circuit, fire and/or electric shock.
- This appliance is intended to be used in household and similar applications such as:
 - staff kitchen areas in shops, offices and other working environments;
 - farmhouses and by clients in hotels, motels, and other residential type environments;
 - bed and breakfast type environments;
 - catering and similar non-retail applications.

 **WARNING!** Any electrical components (plug, power cord, compressor etc.) must be replaced by a certified service agent or qualified electrician.

 **WARNING!** The light bulb supplied with this appliance is a special use light bulb, usable only with the appliance supplied. This special use light bulb is not suitable for domestic lighting.

- The power cord must not be lengthened or altered.
- Make sure that the power plug is not squashed or damaged by the back of the appliance. A squashed or damaged power plug may overheat and cause a fire.
- Make sure the power plug of the appliance is accessible after installation.
- Do not remove the plug by pulling the power cable, pull the power plug.
- If the plug socket is loose, do not insert the power plug. There is a risk of electric shock or fire.
- Check the voltage of the appliance, which is located on the rating label, matches the household voltage.
- You must not operate the appliance without the light bulb.
- This appliance is heavy. Care should be taken when moving it.
- Do not remove or touch items from the freezer compartment if your hands are damp/wet, as this could cause skin abrasions or frost/freezer burns.
- Ice lollies can cause frost burns if consumed straight from the appliance.
- Avoid prolonged exposure of the appliance to direct sunlight.
- Do not put anything hot on the plastic parts of the appliance.
- Do not place food products directly against the rear wall.
- Frozen food must not be re-frozen once it has been thawed out.
- Store pre-packed frozen food in accordance with the manufacturer's instructions.
- The food manufacturer's storage recommendations should be strictly adhered to.
- Do not place carbonated or fizzy drinks in the freezer compartment as it creates pressure on the container, which may cause it to explode, resulting in damage to the appliance.
- To avoid contamination of food, pay attention to the following:
 - Opening the door for long periods can cause a significant increase of the temperature in the compartments of the appliance.
 - Regularly clean surfaces that can come into contact with food and accessible drainage systems.
 - Clean water tanks if they have not been used for 48h; flush the water system connected to a water supply if water has not been drawn for 5 days.
 - Store raw meat and fish in suitable containers in the refrigerator, so that it is not in contact with and cannot drip onto other food.
 - Two-star frozen-food compartments (if they are presented in the appliance) are suitable for storing pre-frozen food, storing, or making ice cream and making ice cubes.
 - One-, two- and three-star compartments (if they are presented in the appliance) are not suitable for the freezing of fresh food.
 - If the appliance is left empty for long periods, switch off, defrost, clean, dry and leave the door open to prevent mould developing within the appliance.
- Before maintenance, switch off the appliance and disconnect the power plug from the mains socket.
- Do not clean the appliance with metal or sharp objects.
- Do not use sharp objects to remove frost from the appliance. Use a plastic scraper.
- Regularly examine the drain in the refrigerator for defrosted water. If necessary, clean the drain. If the drain is blocked, water will collect in the bottom of the appliance.

IMPORTANT: For electrical connection carefully follow the instructions outlined below:

- Unpack the appliance and check for any damage. Do not connect the appliance if damaged. Report possible damages immediately to the place of purchase. In this case retain all packaging.
- It is advisable to wait at least four hours before connecting the appliance, to allow the oil to flow back into the compressor.
- Ensure there is adequate air circulation around the appliance to prevent the unit from overheating. To achieve sufficient ventilation, follow the instructions outlined in the 'Installation' section.
- Wherever possible the spacers of the product should be against a wall to avoid touching or catching warm parts (compressor, condenser) and prevent possible burns.
- The appliance must not be located close to radiators or cookers.
- Make sure that the power plug is accessible after installation of the appliance.
- Any electrical work required for servicing of the appliance should be carried out by a qualified electrician or competent person.
- This product must be serviced by an authorized Service Agent, and only genuine spare parts must be used.

Energy Saving Tips

- Don't put hot food in the appliance.
- Don't pack food close together as this prevents air circulation.
- Make sure food doesn't touch the back of the compartments.
- If electricity goes off, don't open the doors.
- Don't open the doors frequently.
- Don't keep the doors open for prolonged periods of time.
- Don't set the thermostat on exceedingly cold temperatures.
- All accessories, such as drawers and door shelves, should be kept in place for lower energy consumption.

Please Note: This appliance does not contain gases which could damage the ozone layer, in either its refrigerant circuit or insulation materials.

- The appliance shall not be discarded together with the urban refuse and rubbish but disposed of correctly as described in the 'Disposal Information' section.
- The insulation foam contains flammable gasses; the appliance shall be disposed according to the appliance regulations obtained from your local authorities. Avoid damaging the cooling unit, especially the heat exchanger.
- The materials used on this appliance marked by the ♻️ symbol are recyclable.

Please Note: The materials marked with ♻️ symbol are recyclable. Dispose of the packaging in a suitable collection container to recycle it.

WARNING! During use, service and disposal of the appliance, please pay attention to the symbol  shown on the left, yellow or orange in colour, which is located on the rear of appliance (rear panel or compressor). It's the risk of fire warning symbol. There are flammable materials in the refrigerant pipes and compressor. Ensure the appliance is nowhere near any fire sources during use.

TECHNICAL SPECIFICATION

Brand	Statesman
Model Number	MD018362NI
Energy Efficiency Class	E
Annual Energy Consumption	262kWh/annum
Total Net Storage Volume	362L
Freezer Net Storage Volume	125L
Fridge Net Storage Volume	237L
Freezing Capacity	10kg/24h
Applicable Star Rating of Freezer Compartment	4 star
Temperature Rise Time	10hrs
Climate Class	SN/N/ST/T
Noise Emission	39dB
Built-in Appliance	Freestanding

APPLIANCE OVERVIEW

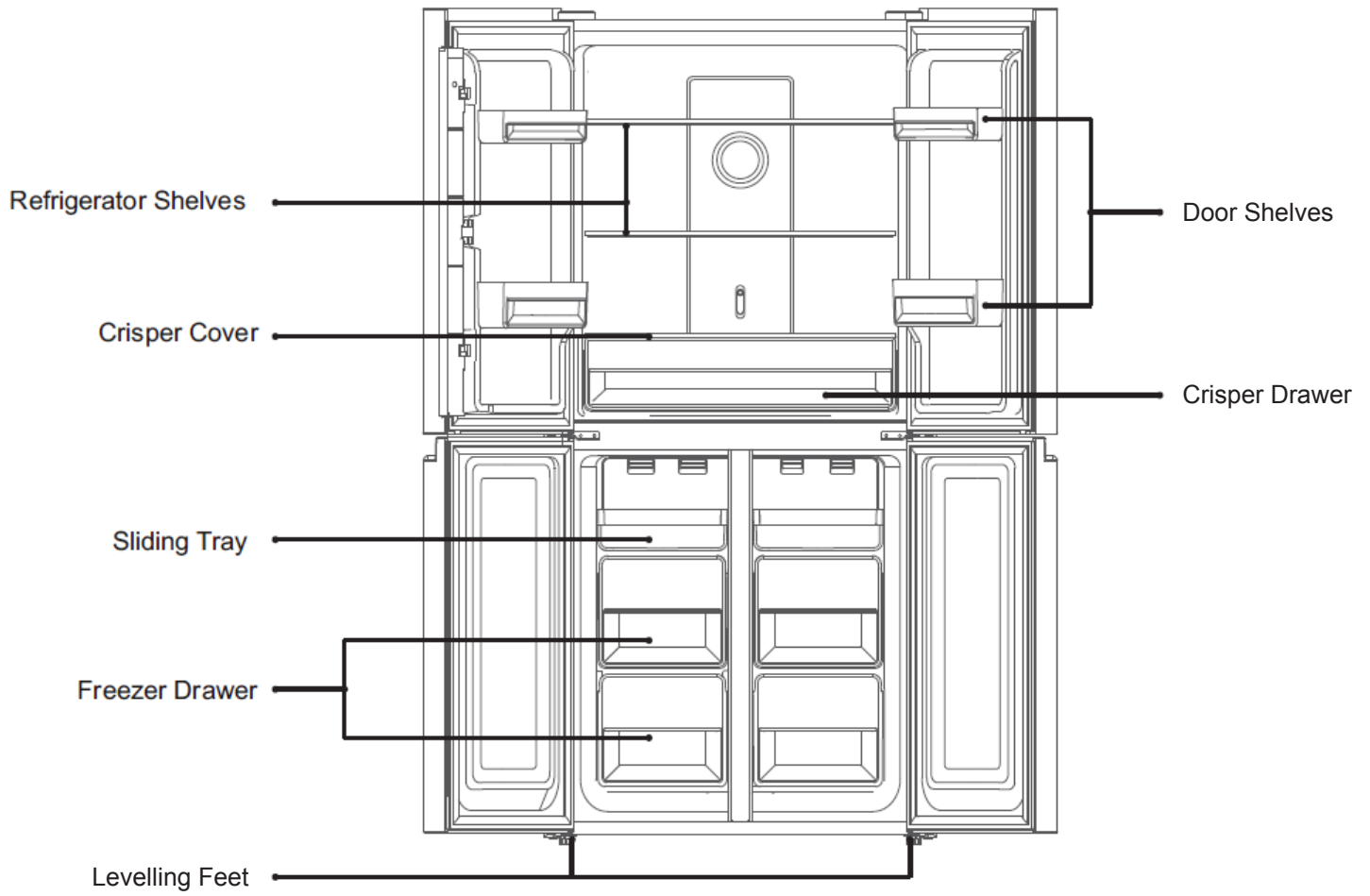

This illustration is only for reference, for details please check your appliance

INSTALLATION

Space Requirement

Please Note: There should be enough space available to fully open all appliance doors.

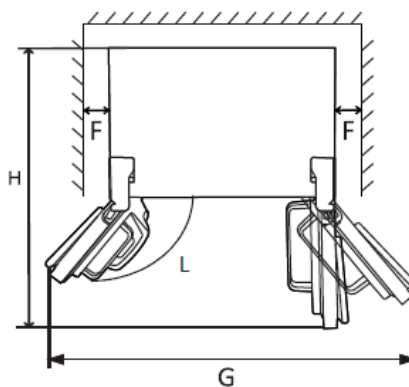
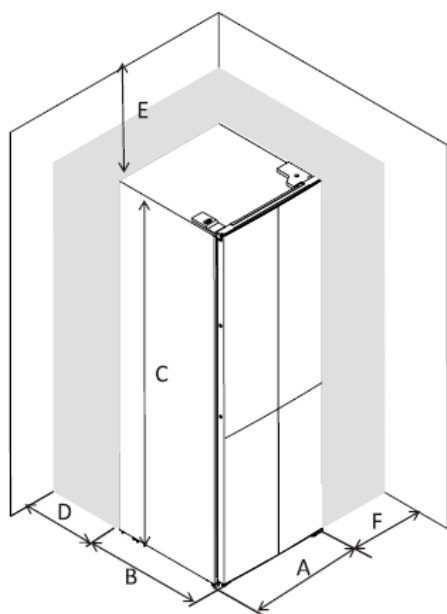

A	795
B	630
C	1800
D	min=50
E	min=50
F	min=50
G	1580
H	1410
L	135°

Levelling the Appliance

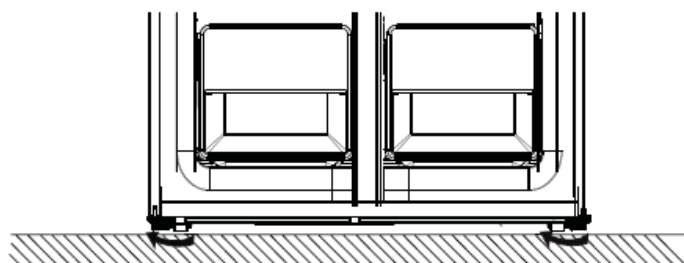
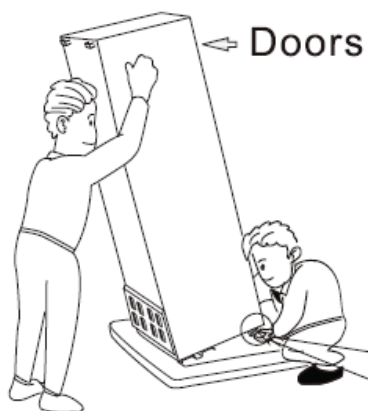

If the unit is not level, the doors and magnetic seal alignments will not be covered properly. Adjust the levelling feet at the base of the unit until the appliance is as level as it can be.

To adjust the levelling feet:

- Turn the feet clockwise to raise the appliance.
- Turn the feet anticlockwise to lower the appliance.

Levelling the Doors

WARNING! Risk of suffocation due to small parts. Please keep washers away from children.

After transportation or when the door shelves are loaded, the upper two doors may not be aligned. There are 3 additional type C washers included with the appliance, which can be used to adjust the upper doors. To do this please follow the below procedure.

1. Before adjusting the doors check the alignment and make sure that the appliance is level.
2. If the top of the upper two doors are not aligned, slightly lift the upper door and clip a type C washer between the bottom of the door and the middle hinge.

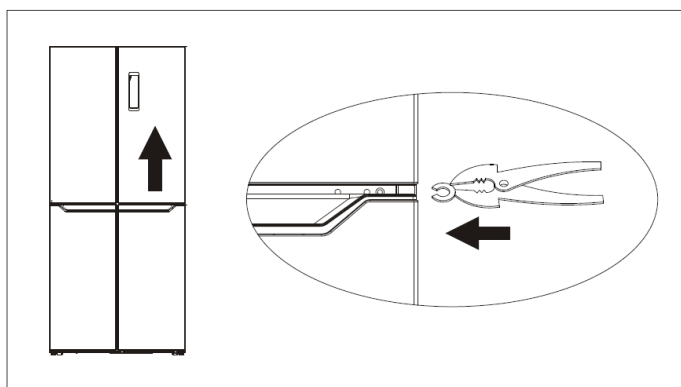

WARNING! Take care not to trap fingers when carrying out this procedure. Always use a tool to insert the washer.

Closing the Appliance Doors

There are rubber blocks between the upper and lower doors to help reduce the impact when the doors close. Do not remove these rubber blocks. If a block is missing, please replace with one of the spares included, by inserting it into the hole in the door as shown below.

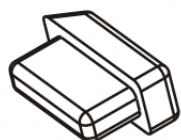

Rubber block

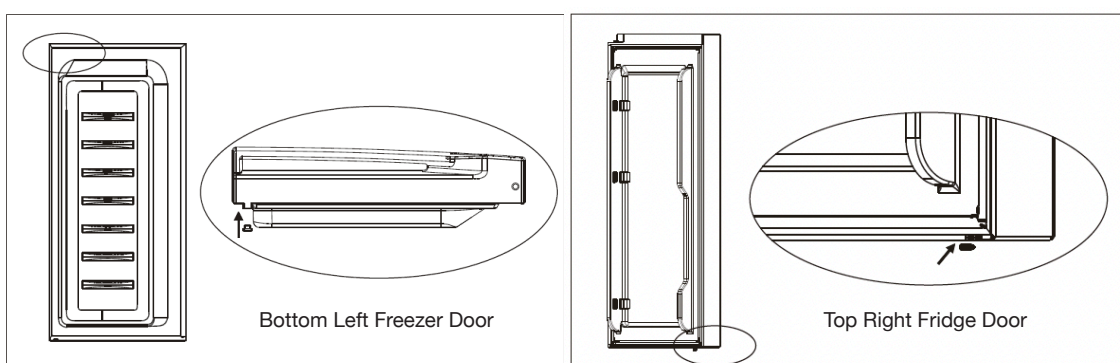

Air Circulation and Positioning

- The appliance must stand vertically on a flat, even surface.
- It is not recommended to stand the appliance on a carpeted surface.
- The appliance should not be installed near any sources of heat such as radiators, boilers, direct sunlight etc.
- Ensure that air can circulate freely around the back of the appliance, to ensure adequate ventilation.

- If the appliance is positioned below an overhanging wall unit, the minimum distance between the top of the cabinet and the wall unit must be at least 50mm. Ideally, however, the appliance should not be positioned below an overhanging wall unit.
- This appliance is not intended to be used as a built-in appliance.
- To level the appliance, use the levelling feet by turning them until the appliance is as level as possible. See the 'Levelling the appliance' section.
- Install the appliance in a location where the ambient temperature corresponds to the climate class indicated on the rating label.

Ambient Room Temperature Limits

Climate Class	Symbol	Ambient Temperature °C
Extended temperature	SN	+10 to +32
Temperature	N	+16 to +32
Subtropical	ST	+16 to +38
Tropical	T	+16 to +43

OPERATING INSTRUCTIONS

Before First Use

- Before using the appliance for the first time, wash the interior and all internal accessories with lukewarm water and some neutral soap to remove the typical smell of a brand-new product, then dry thoroughly.

WARNING! Do not use detergents or abrasive powders, as these will damage the appliance.

- When first switched on or after a period of non-use, set the appliance to run on the coldest settings for 2 hours. The appliance can then be adjusted to the desired temperature and foods can be stored.

Control Panel

1. Temperature of Refrigerator Compartment
 2. Temperature of Freezer Compartment
 3. ECO Mode
 4. Holiday Mode
 5. Super Freeze Mode
 6. Control Panel Lock/Unlock
- A. Temperature Control for Refrigerator Compartment
B. Temperature Control for Freezer Compartment
C. Mode/Control Panel Lock/Unlock

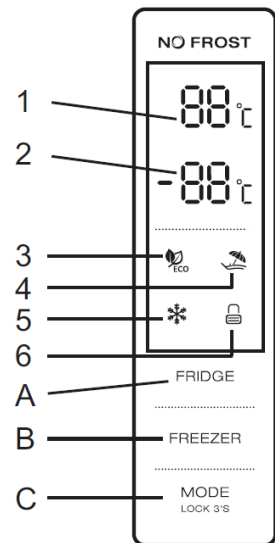

Control Panel Display

- When switching on the appliance, the control panel will illuminate for 3 seconds, and the appliance will operate with the mode and temperature set before it was switched off. Both the preset temperature of the refrigerator compartment and freezer compartment will be shown on the display.
- The control panel will automatically lock 25 seconds after the last operation. After locking, the control panel will stay illuminated for a further 30 seconds before switching off.
- The control panel will light up for 2 minutes once the door of the fridge compartment or freezer compartment is opened (one door signal is sensed at a time).
- The control panel will be lit up by any operation and the light will turn off 2 minutes after the last operation.
- Display during normal operation:
 - Temperature Display of the Refrigerator Compartment (1): Indicates the current set temperature of the refrigerator compartment.
 - Temperature Display of the Freezer Compartment (2): Indicates the current set temperature of the freezer compartment.

Using the Control Panel

Please Note: A short beep will sound after any button is pressed. Buttons are only operational when the control panel is unlocked.

Temperature Control of Refrigerator Compartment (A):

This function can be used in both user defined mode and super freeze mode. Press (FRIDGE) to enter the refrigerator temperature control mode. This key will then flash. Press consecutively to change the temperature in a cycle of “2°C, 3°C, 4°C, 5°C, 6°C, 7°C, 8°C and OFF.” Once at the desired temperature, leave to flash for 5 seconds. This temperature will then set.

Shut-off of the Refrigerator Compartment:

Press (FRIDGE) consecutively until “OFF” is displayed. Leave to flash for 5 seconds, the refrigeration compartment will then stop operating.

Temperature Control of the Freezer Compartment (B):

This function can be used in both user defined mode and holiday mode. Press (FREEZER) to enter the freezer temperature control mode. This key will then flash. Press consecutively to change the temperature in a cycle of -14°C to -22°C. Once at the desired temperature, leave the button to flash for 5 seconds. This temperature will then set.

Control Panel Lock/Unlock (C):

- To lock the control panel: Long press (MODE) for 3 seconds. A beep will sound, and the lock icon (6) will be illuminated. The control panel is now locked.
- To unlock the control panel: Long press (MODE) for 3 seconds. A beep will sound, and the lock icon will turn off. The control panel is now unlocked.

Please Note: The control panel will automatically lock if not used for 25 seconds.

Mode Selection (C):

Press the (MODE) button consecutively, to change the operation mode of the appliance in a cycle of “ECO Mode -Holiday Mode - Super Mode - User Defined Mode. Once the icon for the desired mode is illuminated, leave to flash for 5 seconds, this mode will then be set.

ECO Mode:

Press (MODE) consecutively until the ECO mode icon (3) is illuminated. Leave the icon to flash for 5 seconds. ECO mode will then set, and the icon will remain displayed. The refrigerator compartment temperature will automatically set to 5°C and the freezer compartment temperature will set to -18°C. Press the (MODE) button to exit ECO mode. No other buttons will operate in this mode.

Holiday Mode:

Press the (MODE) button consecutively until the Holiday mode icon (4) is illuminated. Leave the icon to flash for 5 seconds. Holiday mode will then set, and the Holiday mode icon will remain displayed. The refrigerator compartment temperature will automatically set to 17°C in this mode. The (FRIDGE) button cannot be used in this mode. Press the (MODE) button to exit Holiday mode.

Super Freeze Mode:

Press the (MODE) button consecutively until the Super Freeze mode icon (5) is illuminated. Leave the icon to flash for 5 seconds. Super Freeze mode will then set, and the Super Freeze mode icon will remain displayed. The (FREEZER) button cannot be used in this mode.

To exit Super Freeze mode:

- Press the (MODE) button to select another mode.
- Alternatively, after 50 hours in Super Freeze mode, the appliance will automatically revert to the previous settings.

Please Note: If you plan to freeze a large amount of food at the same time, set the Super Freeze mode at least 24 hours before hand.

Recommended Temperature Setting

Temperature Setting Recommendation		
Environment Temperature	Temperature Setting	
Summer (Above 38°C)		Fridge set on 4°C
		Freezer set on -18°C
Normal		Fridge set on 4°C
		Freezer set on -18°C
Winter (Below 16°C)		Fridge set on 4°C
		Freezer set on -18°C

The information above gives users recommendation of temperature setting.

Impact on Food Storage:

Under recommended setting, the best storage time of fridge is no more than 3 days.

Under recommended setting, the best storage time of freezer is no more than 1 month.

The best storage time may reduce under other settings.

Crisper Drawer Temperature Control

- The crisper drawer temperature can be adjusted to best suit the food type being stored.
- Push the slider control upwards to decrease the temperature in the crisper drawer.
- When the slider control is in the 'Crisper' position, the crisper drawer will maintain the appropriate temperature for the storage of fruits and vegetables.
- When the slider is set in the top position, the crisper drawer will maintain the appropriate temperature for the short-term storage of fish and other fresh foods. Foods will not be frozen but will be kept fresh. When in this position it is recommended that the refrigerator temperature should be set at below 4°C.



Positioning of Foods

The table below contains general guidelines on the storage of food in refrigerated appliances.

Refrigerator location	Type of Food
Fridge Door	<ul style="list-style-type: none"> • Foods with natural preservatives such as jams, juices, drinks and condiments. • Do not store perishable foods.
Crisper Drawer	<ul style="list-style-type: none"> • Fruits, herbs and vegetables should be placed separately in the crisper drawer. • Do not store bananas, onions, potatoes, garlic in the refrigerator.
Bottom Fridge Shelf	<ul style="list-style-type: none"> • Raw meat, poultry (for short term storage).
Middle Fridge Shelf	<ul style="list-style-type: none"> • Dairy products and eggs.
Top Fridge Shelf	<ul style="list-style-type: none"> • Foods that do not need cooking, such as ready-to-eat foods, deli meats, leftovers.
Freezer Drawers	<ul style="list-style-type: none"> • Foods for long-term storage. • Top drawer - ice cream, frozen fruit and frozen baked goods. • Middle drawer - frozen vegetables and chips. • Bottom drawer - raw meat, poultry and fish.

Using the Freezer

- The Freezer compartment is suitable for the freezing of fresh foods and the storage of frozen and deep-frozen foods for an extended period.
- Place fresh foods to be frozen in the bottom compartment.
- The maximum quantity of food that can be frozen in 24 hrs, is shown on the rating label.
- The freezing process takes 24 hours. No further food to be frozen should be added during this period.
- Only freeze top quality, fresh and thoroughly cleaned foods that have not passed their expiry date.
- Prepare food in small portions to enable it to be rapidly and completely frozen and to make it possible to subsequently thaw only the quantity required.
- Wrap up the food in aluminium foil or polythene and make sure that the packages are airtight.
- Do not allow fresh, unfrozen foods to touch foods that are already frozen, as this could cause the temperature of the latter to rise.
- Lean foods store better and longer than fatty ones as salt reduces the storage life of food.
- Ice if consumed immediately after removal from the freezer, could cause freezer burns to the skin.
- It is advisable to note the freezing date on each individually stored item to enable you to keep track of the storage time.
- Make sure that shop brought frozen foods have been adequately stored by the retailer and were transferred from the retailer to your freezer in the shortest time possible.
- Do not open the door frequently or leave it open for longer than necessary.
- Once defrosted, food deteriorates rapidly and cannot be refrozen.
- Do not exceed the storage period indicated by the food manufacturer.
- Deep-frozen or frozen food, prior to being used, can be thawed in the fridge compartment or at room temperature, depending on the time available for this operation.
- In the event of accidental defrosting, for example the power has been off for longer than the value shown in the technical specifications under 'Temperature Rise Time,' the defrosted food must be consumed quickly or cooked immediately and then re-frozen after cooking.

Using the Refrigerator

- Do not store warm food or evaporating liquids in the refrigerator.
- Cover or wrap foods, particularly foods with strong flavours.
- Meat (all types): wrap in polythene bags and place on the glass shelves above the crisper drawer. For safety, store in this way for only one or two days at the most.
- Cooked foods should be covered and placed on any shelf.
- Fruit and vegetables should be thoroughly cleaned and then placed in the crisper drawer provided.
- Bananas, potatoes, onions, and garlic, if not packed, must not be kept in the fridge.
- Butter and cheese: these should be placed in airtight containers or wrapped in aluminium foil or polythene bags to exclude as much air as possible.
- Milk bottles: these should have a cap and should be stored on the shelves in the door.

Shelves

The walls of the refrigerator are equipped with a series of runners so that the shelves can be moved and positioned as desired.

Door Shelves

To allow for storage of food packages of various sizes, the door shelves can be placed at different heights. To make these adjustments, gradually pull/push the shelf in the direction of the arrows until it comes free, then reposition the shelf as required. Once in place gently push downwards to secure in position.

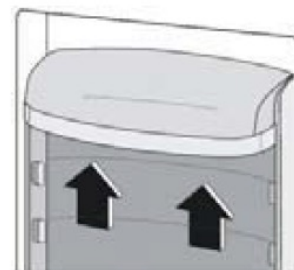
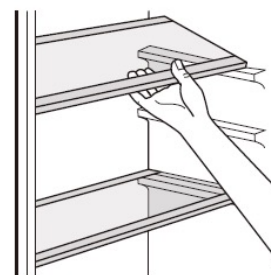

CLEANING AND MAINTENANCE

IMPORTANT: Switch off the electrical supply and remove the plug from the mains socket before carrying out cleaning or maintenance.

 **WARNING!:** Do not use abrasive cloths, powders, household cleaners, bleach, or wax polish to clean the appliance, as these can leave a smell in the appliance and can damage the exterior.

Before First Use

Before using the appliance for the first time, wash the interior and all internal accessories with lukewarm water and some neutral soap to remove the typical smell of a brand-new product, then dry thoroughly.

 **WARNING!:** Never clean the appliance with a steam cleaner. Moisture can accumulate in the electrical components and hot vapours can damage the plastic parts.

 **WARNING!:** Ethereal oils and organic solvents can damage plastic parts, e.g. lemon juice or the juice from orange peel, butyric acid, cleansers that contain acetic acid. Do not allow such substances to come into contact with the appliance.

Interior

1. The interior of the refrigerator should be cleaned regularly to avoid odour.
2. Remove all food from the appliance and cover to help keep cool.
3. Remove all the drawers and shelves carefully from the appliance and wash in warm clean water with a soft cloth and then dry thoroughly. Never replace the drawers when still wet.
4. Use a soft cloth or sponge to clean the inside of the refrigerator, with some baking soda and warm water. Rinse with clean water and wipe clean.
5. Open the door and allow the interior to dry naturally before replacing the shelves and crisper drawer. The appliance should be fully dry before it is switched back on.
6. Plug in, switch on and allow the temperature in the appliance to drop back to an adequate temperature.
7. Replace the food into the appliance.

Exterior

Use a clean, soft cloth dampened in soapy water to wipe the exterior surface of the appliance and then dry thoroughly. Use a vacuum cleaner to remove dust from underneath and from around the compressor which is situated at the back of the appliance. Do this regularly to maintain adequate ventilation. Be careful not to damage the coolant system.

TROUBLE SHOOTING GUIDE

If you are having problems with your appliance, please use our trouble shooting guide below. If you are unable to resolve the issue using this guide please ring our Customer Service Department on 01473 277 508. Please have the model code and purchase information available.

Problem	Possible Cause	Solution
Appliance does not work.	Mains plug is not plugged in or is loose.	Insert mains plug.
	Fuse has blown or is defective.	Check fuse, replace if necessary.
	Socket is defective.	Mains malfunctions are to be corrected by an electrician.
Appliances freezers or cools too much	Temperature is set too cold, or the appliance runs on the Super Freeze mode.	Set the fridge/freezer temperature to a warmer setting temporarily.
The food is not frozen enough.	The temperature is not properly adjusted.	Please refer to the 'Using the Control Panel' section.
	Door was open for an extended period.	Open the door for only as long as necessary.
	A large quantity of warm food was placed in the appliance within the last 24 hours.	Set the fridge/freezer temperature to a colder setting or Super Freeze mode temporarily.
	The appliance is near a heat source.	Please refer to the 'Installation' section.
Unusual noises.	The appliance is not level.	Re-adjust the levelling feet to level.
	The appliance is touching the wall or other objects.	Move the appliance slightly.
	A component, e.g. a pipe, on the rear of the appliance is touching another part of the appliance or the wall.	If necessary, carefully bend the component out of the way.
Heavy build up of frost on the door seal.	The door seal is not airtight.	Carefully warm the leaking sections of the door seal with a hair dryer (on a cool setting). At the same time shape the warmed door seal by hand so that it sits correctly.
Water on the floor.	The water drain hole is blocked.	See the 'Cleaning and Maintenance' section.

FUSE REPLACEMENT (CLASS I)

This appliance must be earthed. Remove the fuse cover with a small flat head screw driver. Take out the fuse and replace with a new fuse of the same Amp. Replace the fuse cover and push back into place.



DISPOSAL INFORMATION

The European Directive 2012/19/EU on Waste Electrical and Electronic Equipment (WEEE), requires that old household electrical appliances must not be disposed of in normal unsorted municipal waste.

Old appliances must be collected separately in order to optimise the recovery and recycling of the materials they contain and reduce the impact on human health and the environment.

The crossed out “wheeled bin” symbol on the product reminds you of your obligation, that when you dispose of the appliance it must be separately collected. Consumers should contact their local authority or retailer for information concerning the correct disposal of their old appliance.



STATESMAN WARRANTY/GUARANTEE TERMS & CONDITIONS

THANK YOU FOR CHOOSING STATESMAN

To help protect your product, we want to give you an additional 12 months warranty. If you register your appliance within 30 days of purchase, we will activate your additional 12 months warranty, giving you **24 months peace of mind**. This means that in the unlikely event you develop a fault or problem with your product we will happily repair or replace the item free of charge. To qualify for the guarantee, the product must be used for domestic household use only and in accordance with the instructions in the user manual. Any misuse of the product will result in the warranty being void. The guarantee does not cover accidental damage, misuse, neglect, tampering or incorrect adjustment or installation. The guarantee will be rendered invalid if the product is resold, has had its serial number or rating label removed (or has an invalid serial number or rating label), or if an unauthorised person has carried out any repairs or alterations.

You can instantly activate your 24 month warranty by visiting www.statesman.warrantyonline.co.uk. Once your registration has been processed you will receive confirmation of your warranty.

The warranty does not cover accessories or consumable parts that require replacement under normal use. This includes shelving, dials, filters, belts and trays etc. In the unlikely event of a breakdown please refer to the Troubleshooting Guide in your user manual and check all plugs, fuses and the electricity supply. If you still require assistance, please contact our Customer Service Department on **01473 277 508** or write to us at the following address:

Customer Service Department:

38 Bluestem Road, Ransomes Industrial Estate, Ipswich, IP3 9RR.

Please quote the Product Code and the PO number on the rating label and give details of the exact fault. We will then decide whether to replace the item.

IMPORTANT NOTE: Before we arrange the replacement, you will be required to return a copy of your proof of purchase. Please retain your original receipt. If an item is replaced within the agreed warranty period, the warranty for the replacement item will be calculated from the purchase date of the original.

If the product is inspected, and no fault is found, or the product is not within the guarantee period you will be charged for the repair and any carriage costs.

STATESMAN

kitchen appliances

UK Address: 38 Bluestem Road, Ransomes Europark, Ipswich, IP3 9RR

EU Address: Castle Electrical Factors Ltd., Dundalk, A91 KA9R, IR

01473 277 508

Disclaimer: Statesman operate a policy of continual improvement and development.
We therefore reserve the right to change/alter the specification and appearance of our appliances without prior notice.
All diagrams and images shown in this manual are for illustration purposes only.