

STATESMAN



R155W - WHITE

R155B - BLACK

R155S - SILVER

55CM UNDER COUNTER FRIDGE WITH 4* ICE BOX

Instruction Manual

Please read these instructions carefully before use and retain for future reference.
Before switching on your appliance – Always check for any damage that may have been caused in transit.

CONTENTS

Important Safety Instructions	2-5
Specification.....	6
Appliance Overview.....	7
Installation	7-10
Operating Instructions.....	10-11
Cleaning and Maintenance.....	11-13
Trouble Shooting Guide.....	14
Fuse Replacement	15
Disposal Information	15

IMPORTANT SAFETY INSTRUCTIONS

Read and follow all of the instructions even if you feel you are familiar with the product, and find a place to keep this manual handy for future reference.

Important: This product is intended for indoor domestic use, for refrigerated and frozen food storage only. When using electrical appliances, basic safety precautions should always be followed:

- Do not operate the appliance with a damaged cord or plug, after it malfunctions or has been dropped or damaged in any way. All electrical repairs must be carried out by a qualified electrician. Inadequate repairs may result in a major source of danger for the user and invalidate the warranty.
- The operating voltage of the appliance is 220-240V at 50Hz. Check the voltage of the appliance matches the household voltage on the rating label and specification for further details.
- Use of an extension cord is not recommended with this product.

- This appliance can be used by children aged from 8 years and above if they have been given supervision or instruction concerning the use of the appliance in a safe way and understand the hazards involved.
- Cleaning and maintenance shall not be made by children
- Keep the appliance and its cord out of reach of children.
- Children should not play with the appliance.
- This appliance can be used by persons with reduced physical, sensory or mental capabilities or lack of experience and knowledge if they have been given supervision or instruction concerning use of the appliance in a safe way and understand the hazards involved.
- Always unplug the appliance before attempting to move it.
- When disconnecting from the electricity supply, pull the plug and not the cord.
- Do not store explosive substances such as aerosol cans with a flammable propellant in this appliance.
- Always keep the ventilation openings clear of obstruction. Should they become blocked, clear them straight away.
- The refrigerant of this product is R600a which is flammable. Ensure when moving the appliance or during installation that the cooling system does not get damaged.

WARNING: The appliance is heavy and care is needed when unpacking and moving it. Get extra help and only hold the appliance by the casing – never hold by the door or the trim.

WARNING: Risk of child entrapment.

Before disposal of the old appliance, make sure that any locking mechanisms have been broken off, doors have been removed but shelves have been left in so that children cannot easily climb inside. Also remove the plug so the appliance is unusable.



WARNING: Risk of fire / flammable materials.

- When positioning the appliance, ensure the supply cord is not trapped or damaged.
- Do not locate multiple portable socket-outlets or portable power supplies at the rear of the appliance.
- Children aged from 3 to 8 years are allowed to load and unload refrigerating appliances.
- To avoid contamination of food, pay attention to the following:
 - opening the door for long periods can cause a significant increase of the temperature in the compartments of the appliance;
 - clean regularly surfaces that can come in contact with food and accessible drainage systems;
 - clean water tanks if they have not been used for 48 hours; flush the water system connected to a water supply if water has not been drawn for 5 days;
 - store raw meat and fish in suitable containers in the refrigerator so that it is not in contact with or drip onto other food;
 - two-star frozen-food compartments are suitable for storing pre-frozen food, storing or making ice-cream and making ice cubes;
 - one-, two- and three-star compartments are not suitable for the freezing of fresh food;
 - if the refrigerating appliance is left empty for long periods, switch off, defrost, clean, dry and leave the door open to prevent mould developing within the appliance.

The table on the next page contains general guidelines on the storage of food in the refrigerator.

Refrigerator location	Type of food
Fridge door	<ul style="list-style-type: none"> • Foods with natural preservatives, such as jams, juices, drinks, condiments. • Do not store perishable foods.
Crisper bin (salad bin)	<ul style="list-style-type: none"> • Fruits, herbs and vegetables should be placed separately in the crisper bin. • Do not store bananas, onions, potatoes, garlic in the refrigerator.
Fridge shelf – bottom Chiller bin	<ul style="list-style-type: none"> • Raw meat, poultry, fish (for short-term storage)
Fridge shelf – middle	<ul style="list-style-type: none"> • Dairy products, eggs
Fridge shelf – top	<ul style="list-style-type: none"> • Foods that do not need cooking, such as ready-to-eat foods, deli meats, leftovers.
Freezer drawer/shelf	<ul style="list-style-type: none"> • Foods for long-term storage. • Bottom drawer/shelf for raw meat, poultry, fish. • Middle drawer/shelf for frozen vegetables, chips. • Top drawer/shelf for ice cream, frozen fruit, frozen baked goods.

SPECIFICATION

Supplier Name / Trade Mark	Statesman
Model Number	R155
Category Type	Refrigerator with one or more fresh-food storage compartments
Energy Efficiency Class	A++
EU Eco-Label Award	N/A
Annual Energy Consumption	136kWh/annum
Freezing Capacity	2kg/24h
Fridge Storage Volume (Litre) and Applicable Star Rating Compartment	97L
Freezer Storage Volume (Litre)	16
Applicable Star Rating Compartment	4 Star
Refrigeration System (Frost Free, Static, Totally No Frost)	Static
Temperature Rise Time	720min
Climate Class	ST/N
This appliance is intended to be used at an ambient temperature between “16” (lowest temperature)°C and “38”(highest temperature) °C	
Noise Emission (dB)	39(db)
Built-in Appliance	N/A
Wine Storage Appliance	N/A
Voltage (V)	220-240V~
Wattage Power (W)	70W
Frequency (Hz)	50Hz
Power Source	AC

Ambient Room Temperature Limits

Class	Symbol	Ambient average temperature °C
Extended temperature	SN	+10 to +32
Temperature	N	+16 to +32
Subtropical	ST	+16 to +38
Tropical	T	+16 to +43

APPLIANCE OVERVIEW

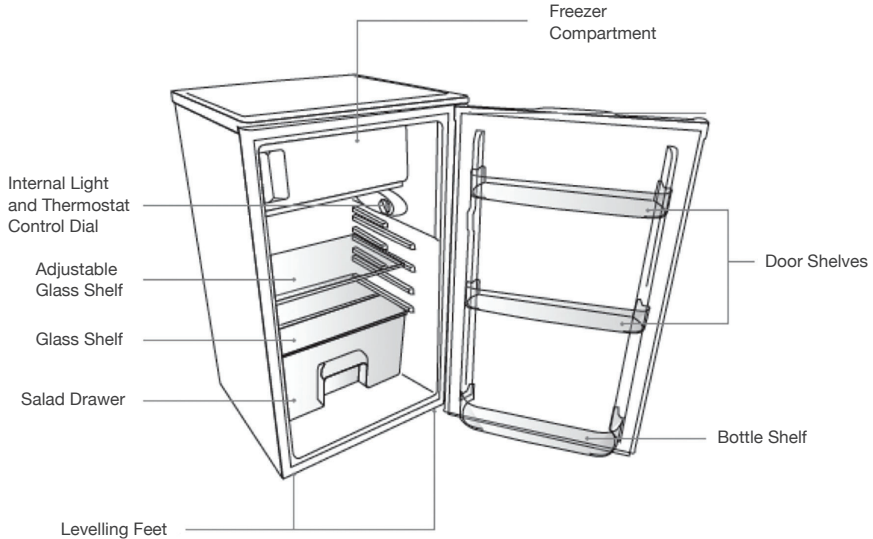

INSTALLATION

Location and air circulation

- The appliance must stand vertically on a flat, even surface, to level the appliance use the levelling feet by turning them until the appliance is as level as possible.
- This appliance has been designed to operate in ambient temperatures between 16°C and 38°C.
- It is not recommended to place this appliance in a room where the temperature is likely to drop below 5°C for prolonged periods, as the internal appliance temperature will not be maintained.
- The appliance should not be placed near sources of heat e.g. cookers, radiators, direct sunlight or in any unheated rooms e.g. garages, or outhouses, as extreme temperatures will affect the performance of your appliance.
- Do not expose the appliance to damp conditions, open air or rain.
- Do not lift the appliance by the pipes or the door when moving.
- It is not recommended to place the appliance in a wall recess, fitted cabinet or furniture as this will not allow adequate ventilation and cause a potential fire hazard.

- Allow 25mm of clearance space at the sides of the appliance and 20mm above the appliance.
- It is not recommended to place the appliance directly against the wall, allow at least a 15mm clearance space at the rear.
- Do not place the appliance in a wall recess, fitted cabinet or furniture as this will not allow adequate ventilation and cause a potential fire hazard.

Providing you follow the recommended ventilation requirements you will:

- Increase the life of the appliance.
- Minimise the risk of condensation on the outside of the appliance.
- Minimise operating noises caused by vibration.

Reverse the door

The appliance door can be fitted to open to either the left or the right depending on its location.

The appliance will have to be tilted and supported in order to carry this out. It is advisable to get some help during this procedure.

Important: Do not lay the appliance flat as this may damage the coolant system. Take care when fitting and tightening screws.

To change the direction of the door, please follow these instructions:

1. Ensure the appliance is unplugged and empty.
2. Remove the 2 Screws on the back of the top cover (Fig 1).
3. Lift the rear of the lid and push forward to remove from the front locators. The top hinge now is accessible (Fig 2).
4. Unscrew the top door hinge located on the top of the door and then remove the top hinge that is holding the door in place. (Fig 3)
5. With help, carefully tilt the unit backwards and rest the unit on something solid to stop slipping.

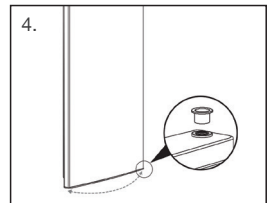
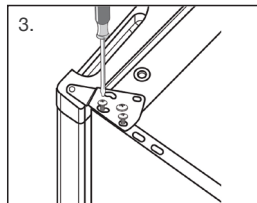
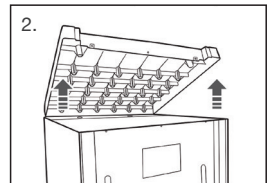
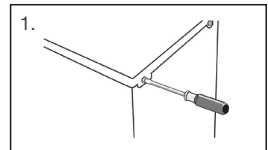

6. Lift the door off the hinge pin and place in a safe place where it will not get damaged

7. Remove the bottom bushing and bottom bushing cap and fit them on the opposite side (Fig 4).

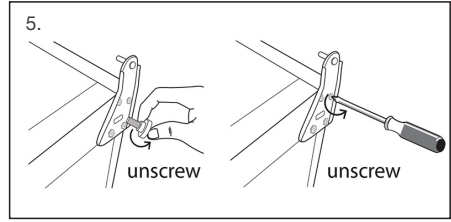

8. Unscrew the bottom hinge (Fig 5).

9. Remove the levelling foot and fit on the opposite side (Fig 6).

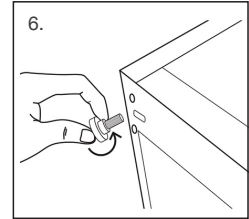

10. Screw the bottom hinge on the opposite side loosely (Fig 7).

11. Carefully slide the door on to the bottom hinge pin.

12. Screw the top hinge loosely (Fig 8).

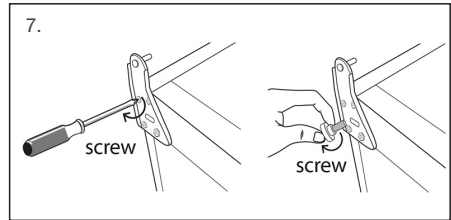

13. Check the fridge door is aligned horizontally and vertically so that the seals are closed on all sides.

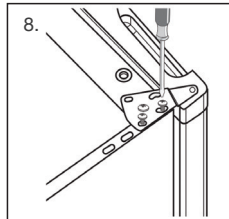

14. Tighten the top hinge. Use a spanner to tighten it if necessary (Fig 9).

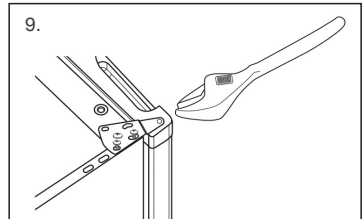

15. Put the top cover back and screw it into place securely (Fig 10).

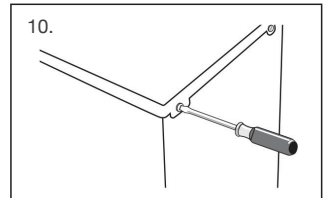

16. With the door closed, check that the door is aligned horizontally and vertically and that the seals are closed on all sides before finally tightening the bottom hinge (Fig 11).

17. Re-adjust the levelling feet as needed.
18. Allow 5 hours for the appliance to stand upright before turning on the appliance to allow coolant gases time to settle after the appliance is in place.

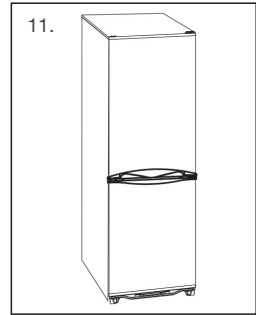

OPERATING INSTRUCTIONS

Before using your appliance

- This appliance must be left to stand in an upright position for at least 5 hours before being switched on for the first time to allow the coolant gases time to settle after the refrigerator is in place.
- Before placing food in the appliance turn on and wait 24 hours, this is to make sure it is working correctly and also to allow for the optimal internal temperature to be reached.
- The interior of the appliance needs to be cleaned prior to use by wiping with a soft cloth and using warm water. Wipe the appliance completely dry before replacing any shelves or salad drawers.
- Once dry, plug the appliance into the mains socket.
- Avoid opening the door for long periods or unnecessarily.
- To maintain adequate air circulation, do not over fill the appliance.
- Allow hot or warm foods to cool to room temperature before storing in the appliance.
- Keep the food packed, wrapped or covered.
- For hygiene reasons, always wrap food using a suitable packaging material, before storing in your appliance to avoid contact with the surface of the appliance.
- Do not place food directly against the rear wall.

Adjusting the Temperature

- The ideal internal temperature of your appliance should be between 0°C to 5°C. This is regulated by the temperature control located internally at the top of the appliance.
- There are 6 settings on the temperature control, with Setting 6 being the coldest, Setting 1 being the warmest and Setting 0 being off.

- Adjust the temperature control which is located inside the appliance to Setting 4, this is the correct setting to use in a room with an average ambient temperature of 20°C.
- Avoid setting the thermostat too high, as this may reduce the temperature to a point where some food begins to freeze. If this happens turn down the thermostat slightly.
- The temperature in the appliances compartment can be monitored by using a fridge thermometer. Do not use a Mercury filled thermometer, as a breakage would cause a health hazard.

CLEANING AND MAINTENANCE

Switch off the electrical supply and remove the plug from the mains socket before cleaning.

Interior

1. The interior of the refrigerator should be cleaned regularly to avoid odor.
2. Remove all food from the appliance and cover to help keep cool.
3. Remove all the drawers carefully from the appliance and wash in warm clean water with a soft cloth and dry thoroughly. Never replace the drawers whilst still wet.
4. Use a soft cloth or sponge to clean the inside of the refrigerator, with two tablespoons of baking soda and a quart of warm water. Rinse with water and wipe clean.
5. For areas that are difficult to clean in the refrigerator (such as narrow sandwiches, gaps or corners), it is recommended to wipe them regularly with a soft rag, soft brush, etc. and when necessary, combined with some auxiliary tools (such as thin sticks) to ensure no contaminant accumulation in these areas.
6. Open the door and allow the interior to dry naturally before replacing shelves and salad crisper.
7. Plug in and switch on and allow the temperature in the appliance to drop back to an adequate temperature.
8. Replace the food in the appliance.

Important: Avoid getting water into the electric components of the appliance i.e. the thermostat) as this may damage your appliance.

Defrosting the Ice Box

After a period of time frost will build up in the ice box. Regular defrosting will therefore be necessary to maintain the efficiency of the appliance.

Defrosting should be carried out if the frost build-up begins to interfere with the food storage. The best time to defrost your cool box is when the amount of food stored is low.

To defrost the ice box, please follow the steps below:

1. Take out the frozen food and store in a spare freezer or wrap well and store in a cool dry place.
2. Unplug the appliance from the mains supply, making sure not to pull the cord. Leave the door open, to speed up the defrosting process, bowls of warm water can be placed inside the appliance to raise the temperature.
3. Remove the ice with a plastic ice scraper. DO NOT use pointed or sharp edged objects such as knives, forks or screw drivers to remove the ice.
4. When all traces of ice have been removed and defrosting is completed, clean away any water and wipe your appliance dry.
5. Clean your appliance as described below, plug in and switch back on, Setting 4 on your temperature control.
6. Allow at least 3 hours for the temperature to return to the adequate temperature before putting the food back into the appliance.

Important: Do not use any mechanical devices or other means to accelerate the defrosting process other than those recommended by the manufacturer.

Exterior

- Use a clean, soft cloth dampened in soapy water to wipe the exterior surface of the appliance and dry thoroughly.
- Use a vacuum cleaner to remove dust from underneath the appliance and from around the compressor which is situated at the back of the appliance, regularly to maintain adequate ventilation. Use caution not to damage the coolant system.

Important: Do not use abrasive cloths, powders, household cleaners, bleach or wax polish to clean the appliance as these can leave a smell in the appliance and can damage the exterior.

Door seal

Use a clean, damp soft cloth to wipe the door seal and in between the creases, avoid damaging the door seal as this will affect the performance of your appliance.

Drainage channel

- The drainage channel must be cleaned regularly to prevent a build-up of impurities; this can be found on the interior back wall of your appliance.
- Use a damp clean cloth and wipe the channel clean, then use a pipe cleaner or similar flexible object to clean the drainage hole to prevent blockages.

Going away

If you are going away and do not want to leave the appliance left on, switch off at the mains socket and remove the plug ensuring not to pull the cord. Remove any food and follow the cleaning instructions in the “Cleaning and Maintenance” section.

Important: Leave the door ajar as this will prevent odours and mould accumulating in the appliance and will allow the appliance to dry completely.

Power Cut

In the event of a power cut keep the appliance door closed to maintain the temperature inside.

Operating sound

The cooling gas which circulates in the cooling circuit may make a slight noise (bubbling sound) even when the compressor is not running. Do not worry this is quite normal.

If these sounds are different check that:

- The appliance is well levelled
- Nothing is touching the rear.
- The stuffs on the appliance are vibrating.

Light replacement

The light is an energy efficient, long life LED, therefore should not need replacing throughout the life of the product. However if it does, it is advised to contact a qualified technician.

1. Remove the light cover
2. Loosen the thermostat knob and fastening screw, and remove the thermostat box assembly
3. Remove the connector
4. Remove the light

TROUBLESHOOTING

If you are having problems with your appliance, please use our troubleshooting guide below. If you are unable to resolve the issue using this guide please ring our Customer Service Department on 0844 848 5861. Please have the model code and purchase information available.

Fault	Possible cause	Solution
Appliance does not work	Temperature control dial is set to "OFF".	Set the dial at other number to switch on the appliance.
	Mains plug is not plugged in or is loose	Insert mains plug.
	Fuse has blown or is defective	Check fuse, replace if necessary.
	Socket is defective	Mains malfunctions are to be corrected by an electrician.
The food is too warm.	Temperature is not properly adjusted.	Please look in the initial Temperature setting section.
	Door was open for an extended period.	Open the door only as long as necessary.
	A large quantity of warm food was placed in the appliance within the last 24 hours.	Turn the temperature regulation to a colder setting temporarily.
	The appliance is near a heat source.	Please look in the installation location section.
Appliance cools too much	Temperature is set too cold.	Turn the temperature regulation knob to a warmer setting temporarily.
Unusual noises	Appliance is not level.	Re-adjust the feet.
	The appliance is touching the wall or other objects.	Move the appliance slightly.
	A component, e.g. a pipe, on the rear of the appliance is touching another part of the appliance or the wall.	If necessary, carefully bend the component out of the way.
Water on the floor	Water drain hole is blocked.	See the Cleaning and care section.
Side panels are hot.	It's normal. Heat exchange parts are in the sides.	Use gloves to touch sides.

DISPOSAL

The European Directive 2012/19/EU on Waste Electrical and Electronic Equipment (WEEE), requires that old household electrical appliances must not be disposed of in normal unsorted municipal waste.

Old appliances must be collected separately in order to optimise the recovery and recycling of the materials they contain and reduce the impact on human health and the environment.

The crossed out “wheeled bin” symbol on the product reminds you of your obligation, that when you dispose of the appliance it must be separately collected. Consumers should contact their local authority or retailer for information concerning the correct disposal of their old appliance.



MAINS PLUG FUSE REPLACEMENT

Earth (green/yellow)

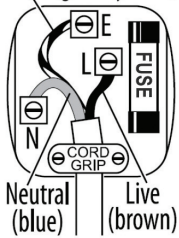

Fuse Replacement (Class I)

This appliance must be earthed. Remove the central screw on the plug and open the shell. Take out the fuse and replace with a new fuse of the same Amp. Install the shell again and tighten the screws.



**38 Bluestem Road,
Ransomes Europark
Ipswich, IP3 9RR**

0844 848 5861

Disclaimer: Statesman operate a policy of continual improvement and development.
We therefore reserve the right to change/alter the specification and appearance of our appliances without prior notice.
All diagrams and images shown in this manual are for illustration purposes only.